













Toggle latch fasteners

Les fermetures rapides - Snelsluitingen



Key to Abbreviations

	Material	NH	No Holes
MS	Mild Steel		Working Load
SS	Stainless Steel Type 304		Ultimate Tensile Strength (see General Fastener Guide)
SS316	Stainless Steel Type 316		Safety Catch Version
	Finish		Padlockable Version
ZN	Zinc Plated Silver Passivate	A B C	Approximate Dimensions (mm) A = length B = width C = height
ZN/YP	Zinc Plated Yellow colour Passivate		3D models and CAD files can be downloaded @ www.protex.com
SF	Self Finish		Approximate Weight (Kg)
BL	Electrophoretic Black Paint		Recommended Catchplate (please order separately where required)
■	Barrel Polished (Stainless Steel)		Optional Sealing Pins (see General Fastener Guide)
∅	Diameter of Fixing Holes (mm)		

Ordering Information

- The full standard range of items shown are normally available from stock.
- The standard options available are shown in the row alongside each part number.
- When ordering please specify:

PART NUMBER + MATERIAL + FINISH + QUANTITY

PLEASE REMEMBER TO ORDER CATCHPLATES SEPARATELY WHERE REQUIRED.

Example of how to order:

LATCH			
Part No. + Material + Finish + Qty			
33-1260	MS	ZN	25
Please remember to order catchplates separately where required:			
CATCHPLATE			
Part No. + Material + Finish + Qty			
05-1058	MS	ZN	25

GENERAL PRODUCT GUIDE



● ULTIMATE TENSILE STRENGTH

The ultimate tensile strength (UTS) for our items is shown in the relevant product tables throughout the catalogue. The figures for the UTS have been determined by tensile tests in a normal working load direction on standard products and do not include any safety factors. A maximum load rate of 30mm per minute was applied throughout the tests. The UTS figures are shown in kilograms and for a Safe Working Load we suggest that approximately half of the ultimate strength figure is used.



● RIGID CLAW FASTENERS

Rigid claw fasteners are manufactured from rigid steel strip or rigid wire forms. Where rigid claw fasteners are fitted we suggest that a rubber type seal is used within the application to provide some resilience between the fastener and catch plate.

If this is not possible we suggest that a spring claw fastener should be used.

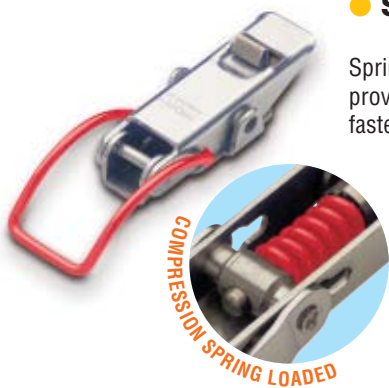

● SPRING CLAW FASTENERS

Spring claw fasteners are manufactured using spring steel curved wire or coil springs and can be used to provide resilience. The degree of spring deflection up to a maximum working load varies between different fasteners and is shown in the relevant product tables within the catalogue.

Extension spring claws pulled beyond their maximum working load will take a permanent set.

Compression spring claws pulled beyond their maximum working load will become coil bound (i.e. rigid) and will no longer act as a spring.

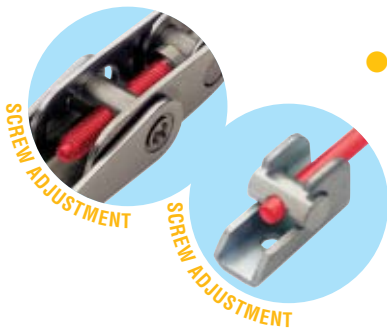

● ADJUSTABLE FASTENERS

Adjustable fasteners incorporate either a screwed spindle or threaded eyebolt and trunnion which produce a minimum 10mm of adjustment. This gives the strength advantages of a rigid fastener while allowing the required tension to be set after fitting.



● CATCH PLATES

The alternative catch plates which are recommended for each fastener are shown in the relevant product tables throughout the catalogue. These may include flat, wide, narrow, 90° crank, reverse crank, joggled and no holes self finish suitable for welding.



Flat



90° Crank



Reverse Crank



Joggled



No Holes self finish

GENERAL PRODUCT GUIDE

● MATERIAL & FINISH



Our products are usually offered in mild steel (**MS**) zinc plated or stainless steel (**SS**). The standard zinc plated finish for each fastener is either silver passivate (**ZN**) or yellow colour passivate (**ZN/YP**) and is shown in the product tables.

Certain fasteners and catchplates are available in mild steel self finish (**SF**) with no holes (**NH**) for welding. Some of the 40- series have self finish bases (**SFB**) for welding with the remaining parts of the fastener zinc plated.

Zinc plate does provide some corrosion resistance for mild steel but when fitting fasteners outside, stainless steel will offer greater corrosion resistance.

We generally manufacture our products from type 304 stainless steel. However, some fasteners and catch plates are available in type 316 as standard, and some as an option. These are shown in the product tables as **SS316** where available.

Some products are also available in mild steel with a black electrophoretic paint (**BL**) as standard. These are also shown in the product tables.



● SAFETY CATCH

To prevent accidental release, certain fasteners are offered with a top mounted or a patented side action safety catch. Please look for the symbol  in the product tables.

● SEALING FACILITY

Many fasteners are available with sealing holes, shown as the symbol  in the product tables, which allows for a sealing pin or wire to be used. We can supply two different styles of sealing pin.

OPTIONAL SEALING PINS

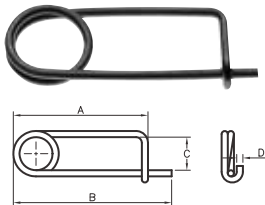

	A	B	C	D(Ø)
1167/7 SS	57	67	15	2.6
502/7 SS	38	43	13	1.8
613/7 SS	33	37	10	1.4

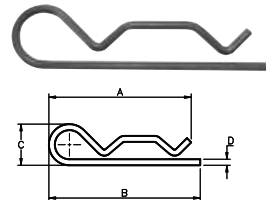

	A	B	C	D(Ø)
1167/9 SS	70	76	19	2.6
502/9 SS	63	66	18	2.6
613/9 SS	55	59	15	2.3

Dimension Guide
(approx. sizes mm)

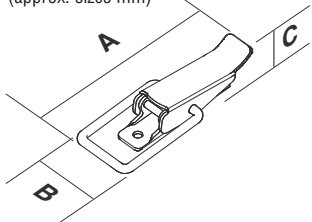

● DIMENSIONS

This catalogue shows the length dimension A, width dimension B and height dimension C in millimetres for each standard product.



Detailed 3D or CAD drawings for most of the range can be viewed and downloaded from our website www.protex.com

10, 15, 20 & 21 - SERIES Rigid & Spring Claw Latches

Part Number	Material	Finish	Diameter of fixing holes (mm)	Max. working load (kg) at max spring deflection (mm)	Ultimate Tensile Strength (kg)	Safety catch version	Padlock version	Dimensions (mm) (approximate sizes)			Approx. weight Kg	Recommended catchplate, order separately where required	Optional sealing pins
								A	B	C			
10-589	MS	ZN	3.0	-	35	-	-	30.2	30.2	8.8	0.010	01-589	-
	MS	SF	NH	-	35	-	-	30.2	30.2	8.8	0.010	01-589NH	
15-531	MS	ZN	3.5	-	70	-	-	35.6	22.0	8.7	0.010	01-531, 02-531, 03-531	-
	SS	■	3.5	-	125	-	-	35.6	22.0	8.7	0.010		
21-1785	SS	■	3.3	-	40	-	-	40.5	22.5	9.0	0.020	01-1785	-
20-505	MS	ZN	3.3	-	170	-	-	50.6	23.0	13.5	0.020	01-504, 02-504 03-504, 01-1658	-
	SS	■	3.3	-	200	-	-	50.6	23.0	13.5	0.020		
20-1658	MS	ZN	3.3	-	170	-	-	46.0	23.0	13.0	0.020	01-504, 02-504 03-504, 01-1658	-
	SS	■	3.3	-	200	-	-	46.0	23.0	13.0	0.020		
20-504 14G	MS	ZN	3.3	19 @ 4.0	90	-	-	56.3	24.4	21.6	0.022	01-504, 02-504 03-504, 01-1658	-
	SS	■	3.3	16 @ 4.0	90	-	-	56.3	24.4	21.6	0.022		
20-561	MS	ZN	3.3	28 @ 4.0	90	-	-	85.7	22.6	19.6	0.230	01-504, 02-504 03-504, 01-1658	-
	SS	■	3.3	11 @ 2.8	90	-	-	85.7	22.6	19.6	0.230		
20-1066	MS	ZN	3.3	27 @ 1.5	90	-	-	50.3	22.2	14.4	0.019	01-504, 02-504 03-504, 01-1658	-
	SS	■	3.3	18 @ 1.0	90	-	-	50.3	22.2	14.4	0.019		
20-1015	MS	ZN	3.3	45 @ 2.0	90	-	-	58.3	21.8	14.4	0.020	01-504, 02-504 03-504, 01-1658	-
	SS	■	3.3	28 @ 1.5	90	-	-	58.3	21.8	14.4	0.020		
20-1165	MS	ZN	3.3	27 @ 2.5	90	-	-	89.7	23.0	21.0	0.023	01-504, 02-504 03-504, 01-1658	-
	SS	■	3.3	18 @ 2.5	90	-	-	89.7	23.0	21.0	0.023		
20-1183	MS	ZN	3.3	68 @ 5.0	90	-	-	62.4	23.0	13.5	0.021	-	-
	SS	■	3.3	22 @ 2.0	90	-	-	62.4	23.0	13.5	0.021		
20-522	MS	ZN	3.3	68 @ 5.0	90	-	-	73.6	23.0	13.5	0.022	-	-
	SS	■	3.3	22 @ 2.0	90	-	-	73.6	23.0	13.5	0.022		
20-1071	MS	ZN	3.3	68 @ 5.0	90	-	-	97.2	23.0	13.5	0.024	-	-
	SS	■	3.3	22 @ 2.0	90	-	-	97.2	23.0	13.5	0.024		

CATCHPLATES *please order separately where required*

Part Number	Material	Finish	Diameter of fixing holes (mm)	Ultimate Tensile Strength (kg)	Dimensions (mm) (approximate sizes)			Approx. weight Kg
					A	B	C	
01-589	MS	ZN	3.0	50	7.9	30.2	6	0.002
	MS	SF	NH	50	7.9	30.2	6	0.002
01-531	MS	ZN	3.5	80	12.7	20.6	5.6	0.002
	SS	■	3.5	115	12.7	20.6	5.6	0.002
02-531	MS	ZN	3.5	80	23	9.5	4.8	0.002
	SS	■	3.5	120	23	9.5	4.8	0.002
03-531	MS	ZN	3.5	80	23.9	9.5	4.8	0.002
	SS	■	3.5	120	23.9	9.5	4.8	0.002
01-1785	SS	■	3.3	100	10.5	19	2.9	0.002
01-504	MS	ZN	3.3	150	9.6	36.6	8	0.005
	SS	■	3.3	180	9.6	36.6	8	0.005
02-504	MS	ZN	3.3	150	28.6	11.1	9.9	0.005
	SS	■	3.3	180	28.6	11.1	9.9	0.005
03-504	MS	ZN	3.3	150	30.8	11.1	8.7	0.005
	SS	■	3.3	180	30.8	11.1	8.7	0.005
01-1658	MS	ZN	3.2	180	14.5	20.5	6.4	0.004
	SS	■	3.2	200	14.5	20.5	6.4	0.004

Dimension Guide (approx. sizes mm)

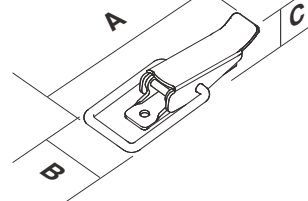

Example of how to order:

LATCH
Part No. + Material + Finish + Qty

10-589 MS ZN 25

Please remember to order catchplates separately where required:

CATCHPLATE

Part No. + Material + Finish + Qty

01-589 MS ZN 25



10-589
&
01-589



15-531



21-1785



10-589NH
&
01-589NH



20-505



20-1658



15-531

20-504 14G



20-561



20-1015 & 01-504

20-1066



20-1015



20-1165



20-1183



20-522



20-1071

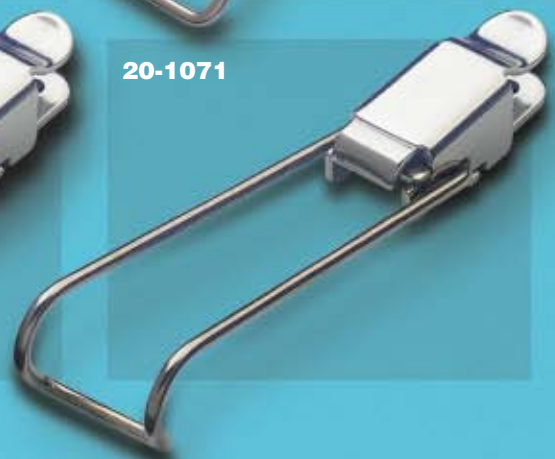

18 - SERIES Rigid & Spring Claw Latches

Part Number	Material	Finish	Diameter of fixing holes (mm)	Max. working load (kg) at max. spring deflection (mm)	Ultimate Tensile Strength (kg)	Safety catch version	Padlock version	Dimensions (mm) (approximate sizes)			Approx. weight Kg	Recommended catchplate, order separately where required	Optional sealing pins
								A	B	C			
18-613	MS	ZN	4.1	-	195	-	-	45.0	38.1	13.1	0.023	01-613, 02-613, 03-613, 07-613	613/7 SS 613/9 SS
	SS	■	4.1	-	300	-	-	45.0	38.1	13.1	0.023		
	MS	BL	4.1	-	195	-	-	45.0	38.1	13.1	0.025	01-613, 02-613, 03-613	
	MS	SF	NH	-	195	-	-	45.0	38.1	13.1	0.023	01-613NH	
18-1204	MS	ZN	4.1	27 @ 1.5	90	-	-	45.1	38.1	15.6	0.021	01-613, 02-613, 03-613, 07-613	613/7 SS 613/9 SS
	SS	■	4.1	18 @ 1.0	90	-	-	45.1	38.1	15.6	0.021		
	MS	BL	4.1	27 @ 1.5	90	-	-	45.1	38.1	15.6	0.023	01-613, 02-613, 03-613	
18-2075	MS	ZN	4.1	45 @ 2.0	90	-	-	54.0	38.1	15.7	0.020	01-613, 02-613, 03-613	613/7 SS 613/9 SS
	SS	■	4.1	28 @ 1.5	90	-	-	54.0	38.1	15.7	0.020		
18-2430	MS	ZN	4.1	27 @ 2.5	90	-	-	84.3	38.1	22.2	0.024	01-613, 02-613, 03-613	613/7 SS 613/9 SS
	SS	■	4.1	18 @ 2.5	90	-	-	84.3	38.1	22.2	0.024		
18-2204	MS	ZN	4.1	27 @ 1.2	90	-	-	45.1	23.0	15.6	0.019	01-613, 02-613, 03-613	613/7 SS 613/9 SS
	SS	■	4.1	18 @ 1.0	90	-	-	45.1	23.0	15.6	0.019		
18-2267	MS	ZN	4.1	19 @ 4.0	90	-	-	51.1	38.1	22.8	0.023	01-613, 02-613, 03-613	613/7 SS 613/9 SS
	SS	■	4.1	16 @ 4.0	90	-	-	51.1	38.1	22.8	0.023		
18-1345	MS	ZN	4.1	30 @ 3.0	70	-	-	56.0	38.1	18.7	0.023	-	613/7 SS 613/9 SS
	SS	■	4.1	9 @ 1.2	60	-	-	56.0	38.1	18.7	0.023		
18-1645	MS	ZN	4.1	20 @ 4.5	80	-	-	88.0	38.1	21.9	0.028	-	613/7 SS 613/9 SS
	SS	■	4.1	10 @ 2.5	70	-	-	88.0	38.1	21.9	0.028		

CATCHPLATES *please order separately where required*

Part Number	Material	Finish	Diameter of fixing holes (mm)	Ultimate Tensile Strength (kg)	Dimensions (mm) (approximate sizes)			Approx. weight Kg
					A	B	C	
01-613	MS	ZN	4.1	150	10.5	38.2	8.0	0.006
	SS	■	4.1	180	10.5	38.2	8.0	0.006
	MS	SF	NH	150	10.5	38.2	8.0	0.006
	MS	BL	4.1	150	10.5	38.2	8.0	0.006
02-613	MS	ZN	4.1	200	31.0	15.9	7.8	0.007
	SS	■	4.1	300	31.0	15.9	7.8	0.007
	MS	BL	4.1	200	31.0	15.9	7.8	0.007
03-613	MS	ZN	4.1	200	30.8	15.9	10.3	0.007
	SS	■	4.1	300	30.8	15.9	10.3	0.007
	MS	BL	4.1	200	30.8	15.9	10.3	0.007
07-613	MS	ZN	4.1	150	29.4	15.9	15.1	0.010
	SS	■	4.1	180	29.4	15.9	15.1	0.010
	MS	BL	4.1	150	29.4	15.9	15.1	0.010

Dimension Guide (approx. sizes mm)

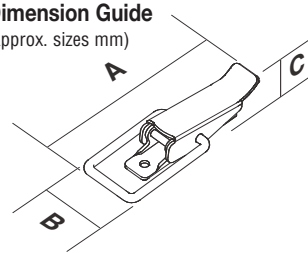

Example of how to order:

LATCH
Part No. + Material + Finish + Qty
18-613 MS ZN 25
Please remember to order catchplates separately where required:

CATCHPLATE
Part No. + Material + Finish + Qty
01-613 MS ZN 25



01-613



02-613



03-613



07-613

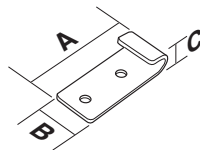

18-613



18-613MSBL



18-613NH



01-613NH

18-1204



18-2075



18-2430



18-1204MSBL



18-2204



18-2267



18-1345



18-1645



27 - SERIES Spring Claw Latches

Part Number	Material	Finish	Diameter of fixing holes (mm)	Max. working load (kg) at max. spring deflection (mm)	Ultimate Tensile Strength (kg)	Safety catch version	Padlock version	Dimensions (mm) (approximate sizes)			Approx. weight Kg	Recommended catchplate, order separately where required	Optional sealing pins
								A	B	C			
27-633	MS	ZN	4.1	45 @ 2.0	90	-	-	71.6	22.3	13.3	0.033	001-600, 02-633, 03-633, 07-613, 00-2075	613/7 SS 613/9 SS
	SS	■	4.1	28 @ 1.5	90	-	-	71.6	22.3	13.3	0.033		
	SS316	■	4.1	28 @ 1.5	90	-	-	71.6	22.3	13.3	0.033		
	MS	BL	4.1	45 @ 2.0	90	-	-	71.6	22.3	13.3	0.034	02-633, 03-633	
27-1570	MS	ZN	4.1	45 @ 2.0	90	✓	-	71.6	22.3	16.7	0.035	001-600, 02-633, 03-633, 07-613, 00-2075	613/7 SS 613/9 SS
	SS	■	4.1	28 @ 1.5	90	✓	-	71.6	22.3	16.7	0.035		
27-1162	MS	ZN	4.1	54 @ 2.5	90	-	-	83.2	22.3	16.3	0.035	001-600, 02-633, 03-633, 07-613, 00-2075	613/7 SS 613/9 SS
	SS	■	4.1	22 @ 1.5	90	-	-	83.2	22.3	16.3	0.035		
27-1162/SC	MS	ZN	4.1	54 @ 2.5	90	✓	-	83.2	22.3	16.7	0.036	001-600, 02-633, 03-633, 07-613, 00-2075	613/7 SS 613/9 SS
	SS	■	4.1	22 @ 1.5	90	✓	-	83.2	22.3	16.7	0.036		
27-1620	MS	ZN	4.1	27 @ 2.5	90	-	-	102.8	22.3	21.5	0.038	001-600, 02-633, 03-633, 07-613, 00-2075	613/7 SS 613/9 SS
	SS	■	4.1	20 @ 2.5	90	-	-	102.8	22.3	21.5	0.038		
27-1620/SC	MS	ZN	4.1	27 @ 2.5	90	✓	-	102.8	22.3	21.5	0.039	001-600, 02-633, 03-633, 07-613, 00-2075	613/7 SS 613/9 SS
	SS	■	4.1	20 @ 2.5	90	✓	-	102.8	22.3	21.5	0.039		
27-1836	MS	ZN	4.1	40 @ 10.6	65	-	-	79.4	28.6	21.1	0.050	001-600, 02-633, 03-633, 07-613, 00-2075	613/7 SS 613/9 SS
	SS	■	4.1	25 @ 10.0	65	-	-	79.4	28.6	21.1	0.050		
27-1837	MS	ZN	4.1	40 @ 10.6	65	✓	-	79.4	28.6	21.1	0.051	001-600, 02-633, 03-633, 07-613, 00-2075	613/7 SS 613/9 SS
	SS	■	4.1	25 @ 10.0	65	✓	-	79.4	28.6	21.1	0.051		

CATCHPLATES *please order separately where required*

Part Number	Material	Finish	Diameter of fixing holes (mm)	Ultimate Tensile Strength (kg)	Dimensions (mm) (approximate sizes)			Approx. weight Kg
					A	B	C	
001-600	MS	ZN	4.1	200	16.5	40.0	11.0	0.010
	SS	■	4.1	400	16.5	40.0	11.0	0.010
02-633	MS	ZN	4.1	150	31.8	15.9	6.8	0.010
	SS	■	4.1	180	31.8	15.9	6.8	0.010
	SS316	■	4.1	180	31.8	15.9	6.8	0.010
	MS	BL	4.1	150	31.8	15.9	6.8	0.010
03-633	MS	ZN	4.1	150	29.4	15.9	10.3	0.010
	SS	■	4.1	180	29.4	15.9	10.3	0.010
	SS316	■	4.1	180	29.4	15.9	10.3	0.010
	MS	BL	4.1	150	29.4	15.9	10.3	0.010
07-613	MS	ZN	4.1	150	29.4	15.9	15.1	0.010
	SS	■	4.1	180	29.4	15.9	15.1	0.010
00-2075	SS	■	4.1	-	26.0	16.0	6.1	0.010

Dimension Guide (approx. sizes mm)

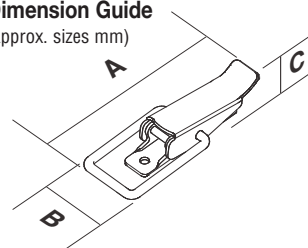

Example of how to order:

LATCH
Part No. + Material + Finish + Qty

27-633 MS ZN 25

Please remember to order catchplates separately where required:

CATCHPLATE
Part No. + Material + Finish + Qty

001-600 MS ZN 25



001-600



02-633



03-633



07-613



00-2075



00-2075 & 02-633



27-633 & 03-633

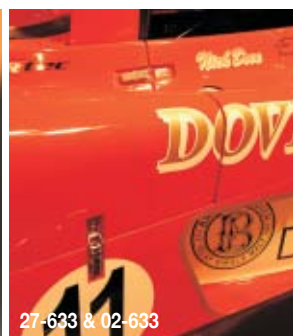

27-633 & 02-633

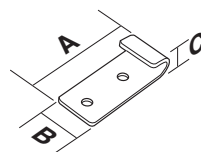

27-633

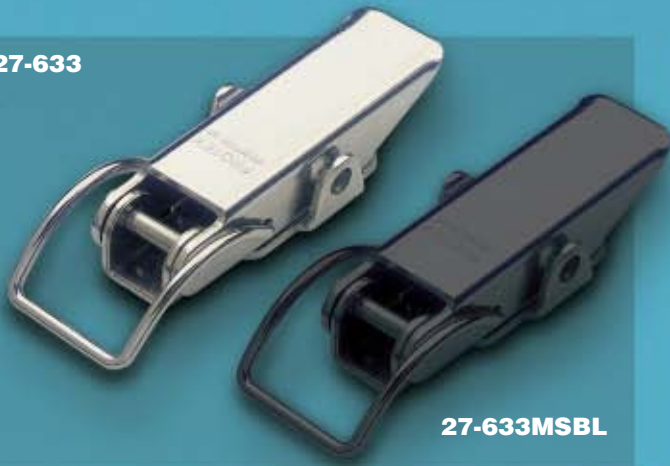

27-633MSBL

27-1570 



27-1162



27-1162/SC 



27-1620



27-1620/SC 













27-1836



27-1837 



27 - SERIES Spring Claw Latches

Part Number	Material 	Finish 	Diameter of fixing holes (mm) 	Max. working load (kg) at max. spring deflection (mm) 	Ultimate Tensile Strength (kg) 	Safety catch version 	Padlock version 	Dimensions (mm) (approximate sizes)			Approx. weight 	Recommended catchplate, order separately where required 	Optional sealing pins 
								A	B	C			
27-645SEAL	MS	ZN	4.1	20 @ 4.5	60	-	-	88	22.3	21.9	0.037	-	613/7 SS 613/9 SS
	SS	■	4.1	11 @ 2.5	50	-	-	88	22.3	21.9	0.037		
	MS	BL	4.1	20 @ 4.5	60	-	-	88	22.3	21.9	0.037		
27-1256	MS	ZN	4.1	20 @ 4.5	60	✓	-	88	22.3	21.9	0.039	-	613/7 SS 613/9 SS
	SS	■	4.1	11 @ 2.5	50	✓	-	88	22.3	21.9	0.039		
27-632SEAL	MS	ZN	4.1	20 @ 4.0	60	-	-	96	22.3	22.9	0.039	-	613/7 SS 613/9 SS
	SS	■	4.1	15 @ 3.0	50	-	-	96	22.3	22.9	0.039		
	MS	BL	4.1	20 @ 4.0	60	-	-	96	22.3	22.9	0.039		
27-632/SC	MS	ZN	4.1	20 @ 4.0	60	✓	-	96	22.3	22.9	0.040	-	613/7 SS 613/9 SS
	SS	■	4.1	15 @ 3.0	50	✓	-	96	22.3	22.9	0.040		
27-1767SEAL	MS	ZN	4.1	12 @ 5.0	50	-	-	134.1	22.3	23.6	0.045	-	613/7 SS 613/9 SS
	SS	■	4.1	8 @ 4.0	40	-	-	134.1	22.3	23.6	0.045		
27-1767/SC	MS	ZN	4.1	12 @ 5.0	50	✓	-	134.1	22.3	23.6	0.046	-	613/7 SS 613/9 SS
	SS	■	4.1	8 @ 4.0	40	✓	-	134.1	22.3	23.6	0.046		

These fasteners are not designed to be used with catchplates.

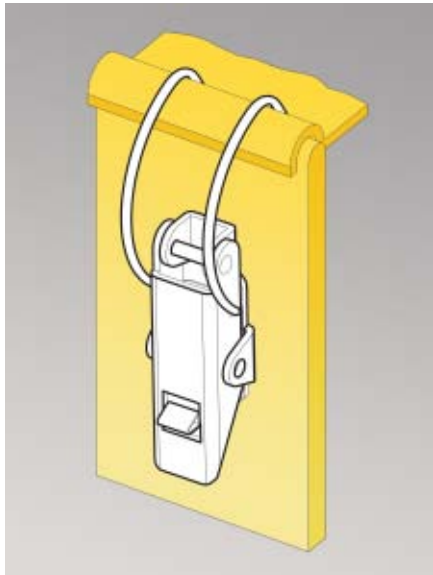

Dimension Guide (approx. sizes mm)

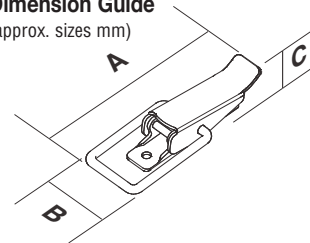

Example of how to order:
LATCH
Part No. + Material + Finish + Qty
27-645SEAL MS ZN 25



27-632



27-632

27-645SEAL



27-1256 



27-632SEAL



27-632/SC 



27-1767SEAL



27-1767/SC 



27-645SEALMSBL



27-632SEALMSBL



27 - SERIES Rigid & Spring Claw Latches

Part Number	Material	Finish	Diameter of fixing holes (mm)	Max. working load (kg) at max. spring deflection (mm)	Ultimate Tensile Strength (kg)	Safety catch version	Padlock version	Dimensions (mm) (approximate sizes)			Approx. weight Kg	Recommended catchplate, order separately where required	Optional sealing pins
								A	B	C			
27-1123	MS	ZN	4.1	-	200	-	-	72.4	22.3	13.3	0.042	001-600, 02-1123, 03-1123, 07-535	613/7 SS 613/9 SS
	SS	■	4.1	-	300	-	-	72.4	22.3	13.3	0.042		
27-1900	MS	ZN	4.1	-	200	✓	-	72.4	22.3	16.7	0.043	001-600, 02-1123, 03-1123, 07-535	613/7 SS 613/9 SS
	SS	■	4.1	-	300	✓	-	72.4	22.3	16.7	0.043		
27-623	MS	ZN	4.1	45 @ 2.0	90	-	-	71.6	34.9	13.9	0.041	05-623, 06-623	613/7 SS 613/9 SS
	SS	■	4.1	28 @ 1.5	90	-	-	71.6	34.9	13.9	0.041		
27-1935	MS	ZN	4.1	54 @ 2.5	90	-	-	83.2	34.9	16.2	0.042	05-623, 06-623	613/7 SS 613/9 SS
	SS	■	4.1	22 @ 1.5	90	-	-	83.2	34.9	16.2	0.042		
27-1288	MS	ZN	4.1	27 @ 2.5	90	-	-	102.8	34.9	21.4	0.044	05-623, 06-623	613/7 SS 613/9 SS
	SS	■	4.1	18 @ 2.5	90	-	-	102.8	34.9	21.4	0.044		
27-2370	MS	ZN	4.1	40 @ 4.0	80	-	-	94.5	22.3	16.4	0.050	-	613/7 SS 613/9 SS
	SS	■	4.1	25 @ 2.0	50	-	-	94.5	22.3	16.4	0.050		
27-2396	MS	ZN	4.1	40 @ 4.0	80	✓	-	94.5	22.3	16.7	0.051	-	613/7 SS 613/9 SS
	SS	■	4.1	25 @ 2.0	50	✓	-	94.5	22.3	16.7	0.051		
27-1236	MS	ZN	4.1	40 @ 4.0	80	-	-	94.5	34.9	16.3	0.054	-	613/7 SS 613/9 SS
	SS	■	4.1	25 @ 2.0	50	-	-	94.5	34.9	16.3	0.054		

CATCHPLATES *please order separately where required*

Part Number	Material	Finish	Diameter of fixing holes (mm)	Ultimate Tensile Strength (kg)	Dimensions (mm) (approximate sizes)			Approx. weight Kg
					A	B	C	
001-600	MS	ZN	4.1	200	16.5	40.0	11.0	0.010
	SS	■	4.1	400	16.5	40.0	11.0	0.010
02-1123	MS	ZN	4.1	200	37.0	16.0	11.0	0.011
	SS	■	4.1	400	37.0	16.0	11.0	0.011
03-1123	MS	ZN	4.1	200	45.0	16.0	15.0	0.014
	SS	■	4.1	400	45.0	16.0	15.0	0.014
07-535	CS	ZN	4.1	300	30.0	16.0	16.5	0.010
	SS	■	4.1	200	30.0	16.0	16.5	0.010
05-623	MS	ZN	4.1	150	31.8	34.9	7.0	0.015
	SS	■	4.1	180	31.8	34.9	7.0	0.015
06-623	MS	ZN	4.1	150	29.5	34.9	10.3	0.015
	SS	■	4.1	180	29.5	34.9	10.3	0.015

Dimension Guide (approx. sizes mm)

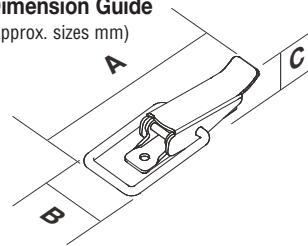

Example of how to order:

LATCH
Part No. + Material + Finish + Qty

27-1123 MS ZN 25
Please remember to order catchplates separately where required:

CATCHPLATE
Part No. + Material + Finish + Qty

001-600 MS ZN 25

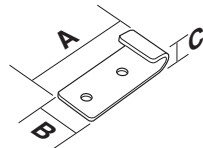

001-600



07-535



02-1123



03-1123



05-623



06-623



27-1123 & 03-1123



27-1123 & 02-1123

27-1123



27-1900 



27-623



27-2370



27-1935



27-2396 



27-1288



27-1236



25 & 29 - SERIES Rigid Latches

Part Number	Material	Finish	Diameter of fixing holes (mm)	Max. working load (kg) at max. spring deflection (mm)	Ultimate Tensile Strength (kg)	Safety catch version	Padlock version	Dimensions (mm) (approximate sizes)			Approx. weight (Kg)	Recommended catchplate, order separately where required	Optional sealing pins
								A	B	C			
29-2642	MS	ZN	4.2	-	300	-	-	57.6	31.7	13.9	0.028	01-535, 02-535, 03-535, 07-535, 08-594	-
	SS	■	4.2	-	350	-	-	57.6	31.7	13.9	0.028		
29-619	MS	ZN	4.2	-	300	-	-	57.6	31.7	13.9	0.028	01-535, 02-535, 03-535, 07-535, 08-594	-
	SS	■	4.2	-	350	-	-	57.6	31.7	13.9	0.028		
29-569	MS	ZN	4.2	-	300	-	✓	57.6	31.7	14.3	0.030	01-535, 02-535, 03-535, 07-535, 08-594	-
	SS	■	4.2	-	350	-	✓	57.6	31.7	14.3	0.030		
29-1394	MS	ZN	4.2	-	300	-	✓	57.6	31.7	14.3	0.030	01-535, 02-535, 03-535, 07-535, 08-594	-
	SS	■	4.2	-	350	-	✓	57.6	31.7	14.3	0.030		
29-1700	MS	ZN	4.2	-	250	-	✓	64.2	18.3	14.2	0.028	01-535, 02-535, 03-535, 07-535, 08-594	-
	SS	■	4.2	-	300	-	✓	64.2	18.3	14.2	0.028		
25-1531	MS	ZN	4.1	-	250	-	-	76.7	34.9	12.7	0.043	01-535, 02-535, 03-535, 07-535, 08-594	-
	SS	■	4.1	-	350	-	-	76.7	34.9	12.7	0.043		
25-507	MS	ZN	4.1	-	250	-	-	76.7	18.7	12.7	0.039	01-535, 02-535, 03-535, 07-535, 08-594	-
	SS	■	4.1	-	350	-	-	76.7	18.7	12.7	0.039		
	MS	BL	4.1	-	250	-	-	76.7	18.7	12.7	0.040		

CATCHPLATES *please order separately where required*

Part Number	Material	Finish	Diameter of fixing holes (mm)	Ultimate Tensile Strength (kg)	Dimensions (mm) (approximate sizes)			Approx. weight (Kg)
					A	B	C	
01-535	MS	ZN	4.1	150	17.1	32.2	11.3	0.010
	MS	BL	4.1	150	17.1	32.2	11.3	0.010
	CS	ZN	4.1	350	17.1	32.2	11.3	0.010
	SS	■	4.1	250	17.1	32.2	11.3	0.010
02-535	MS	ZN	4.1	150	37.7	16.0	11.3	0.010
	MS	BL	4.1	150	37.7	16.0	11.3	0.010
	CS	ZN	4.1	350	36.7	16.0	11.3	0.010
	SS	■	4.1	250	36.7	16.0	11.3	0.010
03-535	MS	ZN	4.1	150	45.8	16.0	14.7	0.011
	MS	BL	4.1	150	45.8	16.0	14.7	0.011
	CS	ZN	4.1	350	45.8	16.0	14.7	0.011
	SS	■	4.1	250	45.8	16.0	14.7	0.011
07-535	CS	ZN	4.1	300	30.0	16.0	16.5	0.011
	SS	■	4.1	200	30.0	16.0	16.5	0.011
08-594	MS	ZN	4.1	100	32.5	31.7	11.0	0.011
	SS	■	4.1	150	32.5	31.7	11.0	0.011

Dimension Guide (approx. sizes mm)

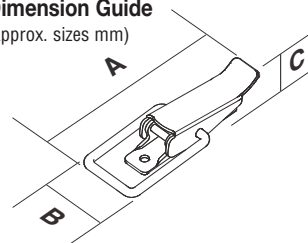

Example of how to order:

LATCH
Part No. + Material + Finish + Qty
29-2642 MS ZN 25
Please remember to order catchplates separately where required:

CATCHPLATE
Part No. + Material + Finish + Qty
01-535 MS ZN 25

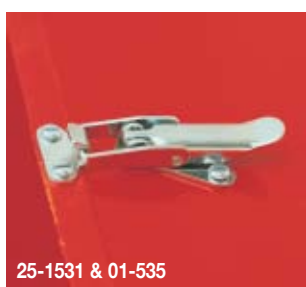
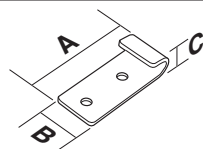
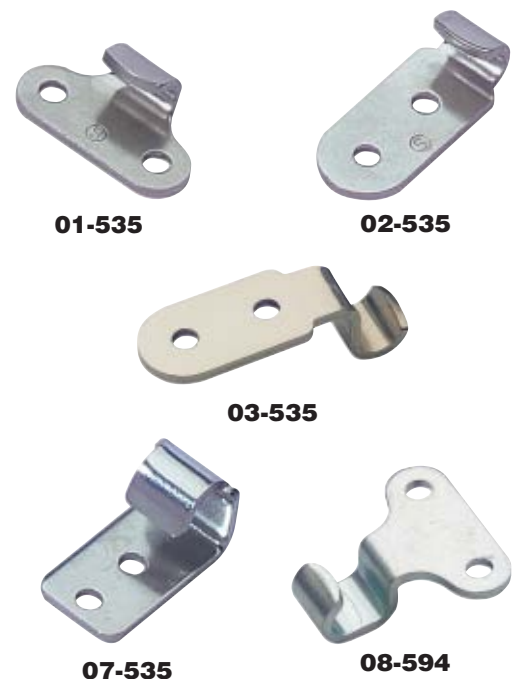

25-1531 & 01-535

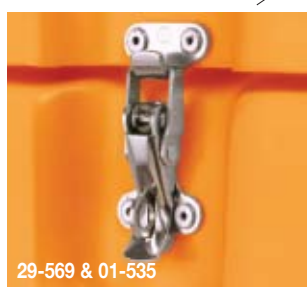

29-569 & 01-535



25-507 & 01-535

29-2642



29-619
with lever return spring



29-569 



29-1394 
with lever return spring



29-1700 



25-1531



25-507



25-507MSBL



50, 55, 200, 201, 250 & 251 - SERIES Spring Loaded & Adjustable Latches

Part Number	Material	Finish	Diameter of fixing holes (mm)	Max. working load (kg) at max. spring deflection (mm)	Ultimate Tensile Strength (kg)	Safety catch version	Padlock version	Dimensions (mm) (approximate sizes)			Approx. weight Kg	Recommended catchplate, order separately where required	Optional sealing pins
								A	B	C			
55-1548	MS	ZN	4.1	11.0 @ 4.0	11	–	–	67.0	20.6	15.4	0.045	01-535, 02-535 03-535, 07-535	–
	SS	■	4.1	11.0 @ 4.0	11	–	–	67.0	20.6	15.4	0.045		
55-1547	MS	ZN	4.1	11.0 @ 4.0	11	–	–	84.0	18.2	17.5	0.053	01-546	–
	SS	■	4.1	11.0 @ 4.0	11	–	–	84.0	18.2	17.5	0.053		

Part Number	Material	Finish	Diameter of fixing holes (mm)	Maximum adjustment (mm)	Ultimate Tensile Strength (kg)	Safety catch version	Padlock version	Dimensions (mm) (approximate sizes)			Approx. weight Kg	Recommended catchplate, order separately where required	Optional sealing pins
								A	B	C			
50-1535	MS	ZN	4.1	10.0	200	–	–	78.0(max)	20.6	15.4	0.041	01-535, 02-535 03-535, 07-535	–
	SS	■	4.1	10.0	300	–	–	78.0(max)	20.6	15.4	0.041		
50-1546	MS	ZN	4.1	10.0	100	–	–	95.0(max)	18.2	17.5	0.055	01-546	–
	SS	■	4.1	10.0	100	–	–	95.0(max)	18.2	17.5	0.055		
200-5000	MS	ZN/YP	4.1	10.0	160	–	–	79.0	30.0	19.5	0.063	01-5000, 02-633	–
	SS	■	4.1	10.0	90	–	–	79.0	30.0	19.5	0.063		
201-5000	MS	ZN/YP	4.1	10.0	160	✓	–	79.0	30.0	19.5	0.068	01-5000, 02-633	–
	SS	■	4.1	10.0	90	✓	–	79.0	30.0	19.5	0.068		
250-5000	MS	ZN/YP	4.1	10.0	160	–	–	85.0	30.0	19.5	0.063	01-5000, 02-633	–
	SS	■	4.1	10.0	90	–	–	85.0	30.0	19.5	0.063		
251-5000	MS	ZN/YP	4.1	10.0	160	✓	–	85.0	30.0	19.5	0.068	01-5000, 02-633	–
	SS	■	4.1	10.0	90	✓	–	85.0	30.0	19.5	0.068		

CATCHPLATES *please order separately where required*

Part Number	Material	Finish	Diameter of fixing holes (mm)	Ultimate Tensile Strength (kg)	Dimensions (mm) (approximate sizes)			Approx. weight Kg
					A	B	C	
01-535	CS	ZN	4.1	350	17.1	32.2	11.3	0.008
	SS	■	4.1	250	17.1	32.2	11.3	0.008
02-535	CS	ZN	4.1	350	36.7	16.0	11.3	0.010
	SS	■	4.1	250	36.7	16.0	11.3	0.010
03-535	CS	ZN	4.1	350	45.8	16.0	14.7	0.011
	SS	■	4.1	250	45.8	16.0	14.7	0.011
07-535	CS	ZN	4.1	300	30.0	16.0	16.5	0.011
	SS	■	4.1	200	30.0	16.0	16.5	0.011
01-546	MS	ZN	4.1	150	16.0	16.0	4.6	0.003
	SS	■	4.1	150	16.0	16.0	4.6	0.003
01-5000	CS	ZN/YP	4.1	200	13.8	15.8	8.4	0.004
	SS	■	4.1	120	13.8	15.8	8.4	0.004
02-633	CS	ZN/YP	4.1	200	31.8	15.9	6.8	0.010
	SS	■	4.1	180	31.8	15.9	6.8	0.010

Dimension Guide (approx. sizes mm)

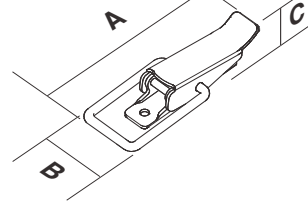

Example of how to order:

LATCH
Part No. + Material + Finish + Qty
55-1548 MS ZN 25
Please remember to order catchplates separately where required:
CATCHPLATE
Part No. + Material + Finish + Qty
01-535 CS ZN 25



01-535



02-535



03-535



07-535



01-546



01-5000



02-633

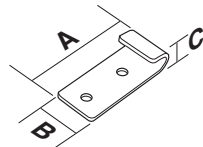

55-1548



55-1547



50-1535



50-1546



200-5000



201-5000 
Shown in
ZN/NYP version

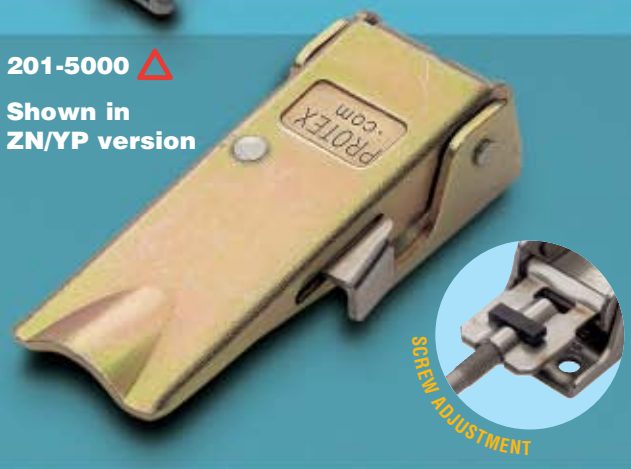

250-5000

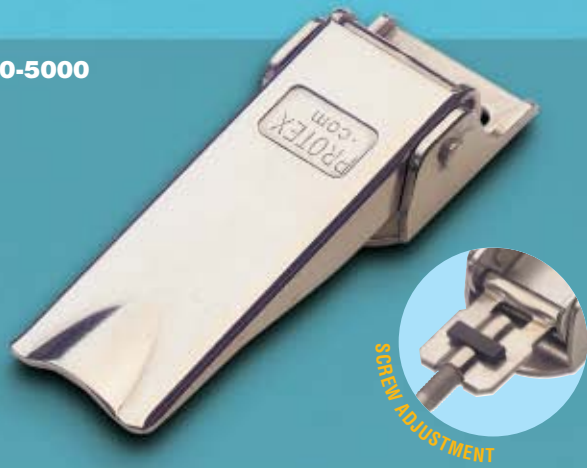

251-5000 

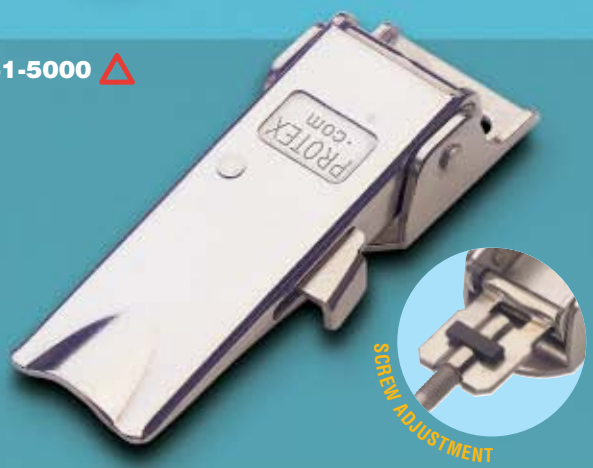

28, 57 & 58 - SERIES Rigid & Spring Claw Latches

Part Number	Material	Finish	Diameter of fixing holes (mm)	Max. working load (kg) at max. spring deflection (mm)	Ultimate Tensile Strength (kg)	Safety catch version	Padlock version	Dimensions (mm) (approximate sizes)			Approx. weight Kg	Recommended catchplate, order separately where required	Optional sealing pins
								A	B	C			
28-1115	MS	ZN	5.5	70 @ 4.5	100	-	-	91.0	48.0	16.7	0.046	04-1115	-
28-2150	MS	ZN	4.1	70 @ 4.5	100	-	-	91.0	19.4	18.4	0.041	04-2150	-
	SS	■	4.1	30 @ 2.5	100	-	-	91.0	19.4	18.4	0.041		
	MS	BL	4.1	70 @ 4.5	100	-	-	91.0	19.4	18.4	0.042		
28-2577	MS	ZN	15.8 x 7.1	80 @ 7.0	150	-	-	124.5	60.5	28.0	0.089	-	-
57-2000	MS	ZN/YP	4.2	-	450	-	-	98.8	24.4	15.0	0.067	01-655, 02-655, 03-655, 007-655	502/7SS 502/9SS
	SS	■	4.2	-	500	-	-	98.8	24.4	15.0	0.067		
58-2000	MS	ZN/YP	4.2	-	450	✓	-	98.8	24.4	18.8	0.070	01-655, 02-655, 03-655, 007-655	502/7SS
	SS	■	4.2	-	500	✓	-	98.8	24.4	18.8	0.070		
58-1182	MS	ZN/YP	4.2	-	350	✓	-	93.4	40.0	18.7	0.066	01-655, 02-655, 03-655, 007-655	502/7SS
	SS	■	4.2	-	400	✓	-	93.4	40.0	18.7	0.066		

CATCHPLATES *please order separately where required*

Part Number	Material	Finish	Diameter of fixing holes (mm)	Ultimate Tensile Strength (kg)	Dimensions (mm) (approximate sizes)			Approx. weight Kg
					A	B	C	
04-1115	MS	ZN	5.5	150	24.7	28.0	10.3	0.010
04-2150	MS	ZN	4.1	150	24.7	28.0	10.3	0.010
	SS	■	4.1	150	24.7	28.0	10.3	0.010
	MS	BL	4.1	150	24.7	28.0	10.3	0.010
01-655	CS	ZN/YP	4.2	400	26.0	40.0	11.2	0.012
	SS	■	4.2	300	26.0	40.0	11.2	0.012
02-655	CS	ZN/YP	4.2	400	33.0	16.0	11.8	0.010
	SS	■	4.2	450	33.0	16.0	11.8	0.010
03-655	CS	ZN/YP	4.2	400	46.2	16.0	31.7	0.015
	SS	■	4.2	450	46.2	16.0	31.7	0.015
007-655	CS	ZN/YP	4.2	300	13.0	40.0	16.0	0.012
	SS	■	4.2	200	13.0	40.0	16.0	0.012

Dimension Guide (approx. sizes mm)

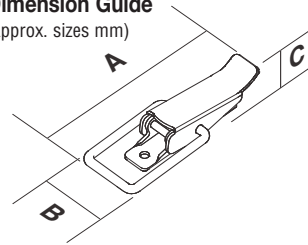

Example of how to order:

LATCH
Part No. + Material + Finish + Qty
28-1115 MS ZN 25
Please remember to order catchplates separately where required:
CATCHPLATE
Part No. + Material + Finish + Qty
04-1115 MS ZN 25



04-1115



04-2150



01-655



02-655



03-655



007-655



58-1182SS & 01-655SS



58-2000SS & 01-655SS

28-1115



28-2577



28-2150



28-2150 MSBL



57-2000



58-2000 

Shown in
ZN/YP version



58-1182 



60 & 61 - SERIES Adjustable Latches

Part Number	Material	Finish	Diameter of fixing holes (mm)	Maximum adjustment (mm)	Ultimate Tensile Strength (kg)	Safety catch version	Padlock version	Dimensions (mm) (approximate sizes)			Approx. weight Kg	Recommended catchplate, order separately where required	Optional sealing pins
								A	B	C			
60-1750	MS	ZN/YP	4.1	10	450	-	-	98.0	24.2	17.0	0.074	01-655, 02-655, 03-655, 03-1655, 06-655, 007-655	502/7 SS
	SS	■	4.1	10	500	-	-	98.0	24.2	17.0	0.074		502/9 SS
61-1750	MS	ZN/YP	4.1	10	450	✓	-	98.0	24.2	20.7	0.078	01-655, 02-655, 03-655, 03-1655, 06-655, 007-655	502/7 SS
	SS	■	4.1	10	500	✓	-	98.0	24.2	20.7	0.078		
60-1610	MS	ZN/YP	4.1	10	450	-	-	98.0	40.0	17.0	0.078	01-655, 02-655, 03-655, 03-1655, 06-655, 007-655	502/7 SS
	SS	■	4.1	10	500	-	-	98.0	40.0	17.0	0.078		502/9 SS
61-1610	MS	ZN/YP	4.1	10	450	✓	-	98.0	40.0	20.7	0.082	01-655, 02-655, 03-655, 03-1655, 06-655, 007-655	502/7 SS
	SS	■	4.1	10	500	✓	-	98.0	40.0	20.7	0.082		
60-655M1	MS	ZN/YP	4.1	10	350	-	-	93.0	40.0	17.0	0.071	01-655, 02-655, 03-655, 03-1655, 06-655, 007-655	502/7 SS
	SS	■	4.1	10	400	-	-	93.0	40.0	17.0	0.071		502/9 SS
61-655M1	MS	ZN/YP	4.1	10	350	✓	-	93.0	40.0	20.7	0.075	01-655, 02-655, 03-655, 03-1655, 06-655, 007-655	502/7 SS
	SS	■	4.1	10	400	✓	-	93.0	40.0	20.7	0.075		
60-658M1	MS	ZN/YP	4.1	10	250	-	-	114.0	40.0	17.0	0.088	01-658	502/7 SS
	SS	■	4.1	10	175	-	-	114.0	40.0	17.0	0.088		502/9 SS
61-658M1	MS	ZN/YP	4.1	10	250	✓	-	114.0	40.0	20.7	0.092	01-658	502/7 SS
	SS	■	4.1	10	175	✓	-	114.0	40.0	20.7	0.092		

CATCHPLATES *please order separately where required*

Part Number	Material	Finish	Diameter of fixing holes (mm)	Ultimate Tensile Strength (kg)	Dimensions (mm) (approximate sizes)			Approx. weight Kg
					A	B	C	
01-655	CS	ZN/YP	4.1	400	26	40	11.2	0.012
	SS	■	4.1	300	26	40	11.2	0.012
02-655	CS	ZN/YP	4.1	400	33	16	11.8	0.010
	SS	■	4.1	450	33	16	12.3	0.010
03-655	CS	ZN/YP	4.1	400	40.2	16	31.7	0.015
	SS	■	4.1	450	40.2	16	32	0.015
03-1655	CS	ZN/YP	4.1	400	40.2	16	32	0.017
	SS	■	4.1	450	40.2	16	32	0.017
06-655	CS	ZN/YP	4.1	400	29	40	10	0.012
	SS	■	4.1	300	29	40	10	0.012
007-655	CS	ZN/YP	4.1	300	13	40	16	0.012
	SS	■	4.1	200	13	40	16	0.012
01-658	CS	ZN/YP	4.1	400	23	40	7.1	0.012
	SS	■	4.1	300	23	40	7.1	0.012

Dimension Guide (approx. sizes mm)

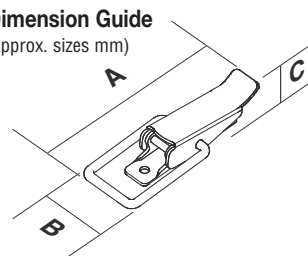

Example of how to order:

LATCH
Part No. + Material + Finish + Qty

60-1750 MS ZN/YP 25

Please remember to order catchplates separately where required:

CATCHPLATE

Part No. + Material + Finish + Qty

01-655 CS ZN/YP 25



01-655



02-655



03-655

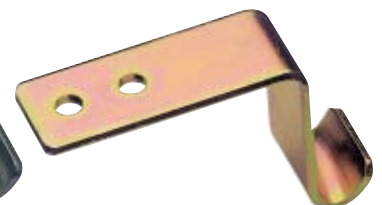

03-1655
Shown in ZN/YP version



06-655



007-655



01-658



60-655M1SS & 007-655SS

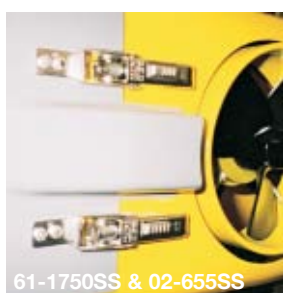

61-1750SS & 02-655SS



61-655M1SS & 01-655SS

60-1750



61-1750 
Shown in
ZN/YP version



60-1610



61-1610 



60-658 M1



61-658 M1 



60-655 M1



61-655 M1 

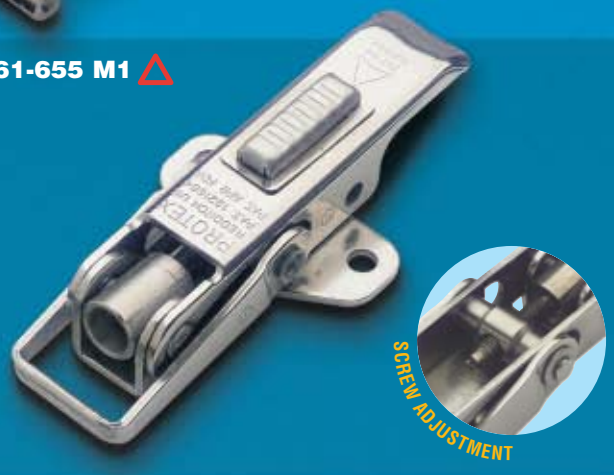

30 - SERIES Rigid Latches

Part Number	Material	Finish	Diameter of fixing holes (mm)	Max. working load (kg) at max. spring deflection (mm)	Ultimate Tensile Strength (kg)	Safety catch version	Padlock version	Dimensions (mm) (approximate sizes)			Approx. weight Kg	Recommended catchplate, order separately where required	Optional sealing pins
								A	B	C			
30-502	MS	ZN	5.1	-	450	-	-	105.9	38.9	18.3	0.070	01-502, 02-502, 03-502, 03-1692, 03-544, 03-2480, 03-1619, 007-1058, 08-502	502/7 SS 502/9 SS
	SS	■	5.1	-	550	-	-	105.9	38.9	18.3	0.070		
	MS	BL	5.1	-	450	-	-	105.9	38.9	18.3	0.070		
30-570	MS	ZN	5.1	-	450	-	✓	105.9	38.9	23.8	0.078	01-502, 02-502, 03-502, 03-1692, 03-544, 03-2480, 03-1619, 007-1058, 08-502	502/7 SS 502/9 SS
	SS	■	5.1	-	550	-	✓	105.9	38.9	23.8	0.078		
	MS	BL	5.1	-	450	-	✓	105.9	38.9	23.8	0.078		
30-588LP	MS	ZN	5.1	-	450	-	-	124.6	38.9	18.3	0.081	01-502, 02-502, 03-502, 03-1692, 03-544, 03-2480, 03-1619, 007-1058, 08-502	502/7 SS 502/9 SS
	SS	■	5.1	-	550	-	-	124.6	38.9	18.3	0.081		
30-588	MS	ZN	5.1	-	450	-	✓	124.6	38.9	23.8	0.084	01-502, 02-502, 03-502, 03-1692, 03-544, 03-2480, 03-1619, 007-1058, 08-502	502/7 SS 502/9 SS
	SS	■	5.1	-	550	-	✓	124.6	38.9	23.8	0.084		
30-560	MS	ZN	5.1	-	450	-	-	143.3	38.9	18.3	0.084	01-502, 02-502, 03-502, 03-1692, 03-544, 03-2480, 03-1619, 007-1058, 08-502	502/7 SS 502/9 SS
	SS	■	5.1	-	550	-	-	143.3	38.9	18.3	0.084		
30-1850	MS	ZN	5.1	-	450	-	✓	143.3	38.9	23.6	0.090	01-502, 02-502, 03-502, 03-1692, 03-544, 03-2480, 03-1619, 007-1058, 08-502	502/7 SS 502/9 SS
	SS	■	5.1	-	550	-	✓	143.3	38.9	23.8	0.090		

CATCHPLATES *please order separately where required*

Part Number	Material	Finish	Diameter of fixing holes (mm)	Ultimate Tensile Strength (kg)	Dimensions (mm) (approximate sizes)			Approx. weight Kg
					A	B	C	
01-502	MS	ZN	5.1	450	22.2	60.3	11.9	0.030
	MS	BL	5.1	450	22.2	60.3	11.9	0.030
	SS	■	5.1	700	22.2	60.3	11.9	0.030
02-502	MS	ZN	5.1	450	55.6	24.0	12.7	0.034
	SS	■	5.1	700	55.6	24.0	12.7	0.034
03-502	MS	ZN	5.1	500	56.6	24.0	15.1	0.034
	MS	BL	5.1	500	56.6	24.0	15.1	0.034
	SS	■	5.1	700	56.6	24.0	15.1	0.034
03-1692	MS	ZN	5.1	500	63.2	24.0	24.6	0.042
	SS	■	5.1	700	63.2	24.0	24.6	0.042
03-544	MS	ZN	5.1	500	61.1	24.0	51.0	0.053
	SS	■	5.1	700	61.1	24.0	51.0	0.053
03-2480	MS	ZN	5.1	500	110.1	24.0	15.0	0.053
03-1619	MS	SF	NH	500	39.4	24.0	16.0	0.026
007-1058	MS	ZN	5.1	450	20.0	51.0	19.0	0.033
	SS	■	5.1	550	20.0	51.0	19.0	0.033
08-502	MS	ZN	5.1	450	62.0	24.0	14.0	0.034
	SS	■	5.1	600	62.0	24.0	14.0	0.034

Dimension Guide (approx. sizes mm)

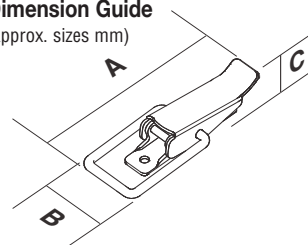

Example of how to order:

LATCH
Part No. + Material + Finish + Qty

30-502 MS ZN 25

Please remember to order catchplates separately where required:

CATCHPLATE
Part No. + Material + Finish + Qty

01-502 MS ZN 25



01-502

02-502



03-502

03-1692



03-544

03-2480



03-1619

007-1058

08-502



30-588LP & 01-502

30-570 & 06-1058

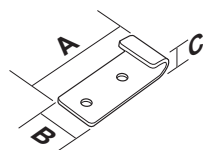

In addition the Catchplates on page 26 may also be used

30-502



30-570 



30-502MSBL



30-570MSBL 



30-588LP



30-588 



30-560



30-1850 



30 - SERIES Rigid & Spring Claw Latches

Part Number	Material	Finish	Diameter of fixing holes (mm)	Max. working load (kg) at max. spring deflection (mm)	Ultimate Tensile Strength (kg)	Safety catch version	Padlock version	Dimensions (mm) (approximate sizes)			Approx. weight Kg	Recommended catchplate, order separately where required	Optional sealing pins
								A	B	C			
30-602	MS	ZN	5.1	180 @ 4.0	450	–	–	105.5	34.0	20.0	0.070	01-602, 02-502, 03-502, 007-502, 08-502	502/7 SS 502/9 SS
	SS	■	5.1	75 @ 2.0	450	–	–	105.5	34.0	20.0	0.070		
	MS	BL	5.1	180 @ 4.0	450	–	–	105.5	34.0	20.0	0.070	01-602, 02-502, 03-502	
30-521	MS	ZN	5.1	40 @ 10.0	100	–	–	95.2	31.8	21.5	0.080	01-602, 02-502, 03-502, 08-502	502/7 SS 502/9 SS
	SS	■	5.1	30 @ 10.0	80	–	–	95.2	31.8	21.5	0.080		
30-693	MS	ZN	5.1	40 @ 10.0	100	–	✓	95.2	31.8	23.8	0.082	01-602, 02-502, 03-502, 08-502	502/7 SS 502/9 SS
	SS	■	5.1	30 @ 10.0	80	–	✓	95.2	31.8	23.8	0.082		
30-506	MS	ZN	5.1	–	300	–	–	116.0	29.5	18.4	0.094	–	502/7 SS 502/9 SS
	SS	■	5.1	–	200	–	–	116.0	29.5	18.4	0.094		
30-606	MS	ZN	5.1	–	300	–	✓	116.0	29.5	23.8	0.096	–	502/7 SS 502/9 SS
	SS	■	5.1	–	200	–	✓	116.0	29.5	23.8	0.096		
30-1021	MS	ZN	5.1	–	250	–	–	121.5	29.5	18.4	0.094	–	502/7 SS 502/9 SS
	SS	■	5.1	–	200	–	–	121.5	29.5	18.4	0.094		
30-585	MS	ZN	5.1	–	200	–	–	135.9	29.5	18.4	0.103	–	502/7 SS 502/9 SS
	SS	■	5.1	–	125	–	–	135.9	29.5	18.4	0.103		

CATCHPLATES *please order separately where required*

Part Number	Material	Finish	Diameter of fixing holes (mm)	Ultimate Tensile Strength (kg)	Dimensions (mm) (approximate sizes)			Approx. weight Kg
					A	B	C	
01-602	MS	ZN	5.1	450	26.0	24.0	12.0	0.023
	MS	BL	5.1	450	26.0	24.0	12.0	0.023
	SS	■	5.1	600	26.0	24.0	12.0	0.023
02-502	MS	ZN	5.1	450	55.6	24.0	12.7	0.034
	MS	BL	5.1	450	55.6	24.0	12.7	0.034
	SS	■	5.1	700	55.6	24.0	12.7	0.034
03-502	MS	ZN	5.1	500	56.6	24.0	15.1	0.034
	MS	BL	5.1	500	56.6	24.0	15.1	0.034
	SS	■	5.1	700	56.6	24.0	15.1	0.034
007-1058	MS	ZN	5.1	450	20.0	51.0	19.0	0.033
	SS	■	5.1	550	20.0	51.0	19.0	0.033
08-502	MS	ZN	5.1	450	62.0	24.0	14.0	0.034
	SS	■	5.1	620	62.0	24.0	14.0	0.034

Dimension Guide (approx. sizes mm)

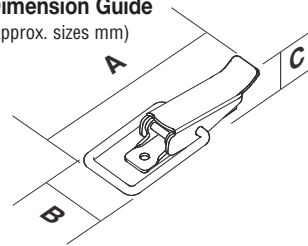

Example of how to order:

LATCH
Part No. + Material + Finish + Qty

30-602 MS ZN 25

Please remember to order catchplates separately where required:

CATCHPLATE
Part No. + Material + Finish + Qty

01-602 MS ZN 25



01-602



02-502



03-502



007-1058



08-502

In addition the Catchplates on pages 22 and 26 may also be used

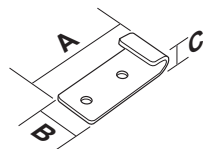

30-506



30-585

30-602



30-602MSBL



30-521



30-693 



30-506



30-606 



30-1021



30-585



33, 38 - SERIES Rigid & Spring Claw Latches

Part Number	Material	Finish	Diameter of fixing holes (mm)	Max. working load (kg) at max. spring deflection (mm)	Ultimate Tensile Strength (kg)	Safety catch version	Padlock version	Dimensions (mm) (approximate sizes)			Approx. weight	Recommended catchplate, order separately where required	Optional sealing pins
								A	B	C			
33-1260	MS	ZN	5.1	-	450	-	-	113.3	38.1	17.3	0.109	05-1058, 06-1058, 02-1260, 007-1058, 08-1058	1167/7 SS
	SS 316	■	5.1	-	550	-	-	113.3	38.1	17.3	0.109		1167/9 SS
38-1260	MS	ZN	5.1	-	450	✓	-	113.3	38.1	17.3	0.112	05-1058, 06-1058, 02-1260, 007-1058, 08-1058	1167/7 SS
	SS 316	■	5.1	-	550	✓	-	113.3	38.1	17.3	0.112		1167/9 SS
33-5880	MS	ZN	5.1	-	450	-	-	146.7	38.1	17.3	0.119	05-1058, 06-1058, 02-1260, 007-1058, 08-1058	1167/7 SS
	SS 316	■	5.1	-	550	-	-	146.7	38.1	17.3	0.119		1167/9 SS
38-5880	MS	ZN	5.1	-	450	✓	-	146.7	38.1	17.3	0.122	05-1058, 06-1058, 02-1260, 007-1058, 08-1058	1167/7 SS
	SS 316	■	5.1	-	550	✓	-	146.7	38.1	17.3	0.122		1167/9 SS
33-2556	MS	ZN	5.1	150 @ 3.0	250	-	-	145.0	38.1	17.3	0.124	05-1058, 06-1058, 02-1260, 007-1058, 08-1058	1167/7 SS
	SS	■	5.1	150 @ 3.0	250	-	-	145.0	38.1	17.3	0.124		1167/9 SS
38-2556	MS	ZN	5.1	150 @ 3.0	250	✓	-	145.0	38.1	17.3	0.127	05-1058, 06-1058, 02-1260, 007-1058, 08-1058	1167/7 SS
	SS	■	5.1	150 @ 3.0	250	✓	-	145.0	38.1	17.3	0.127		1167/9 SS

CATCHPLATES *please order separately where required*

Part Number	Material	Finish	Diameter of fixing holes (mm)	Ultimate Tensile Strength (kg)	Dimensions (mm) (approximate sizes)			Approx. weight
					A	B	C	
05-1058	MS	ZN	5.1	450	34.9	50.8	12.7	0.033
	SS	■	5.1	620	34.9	50.8	12.7	0.033
	SS316	■	5.1	620	34.9	50.8	12.7	0.033
06-1058	MS	ZN	5.1	450	35.4	50.8	15.9	0.033
	SS	■	5.1	620	35.4	50.8	15.9	0.033
	SS316	■	5.1	620	35.4	50.8	15.9	0.033
02-1260	MS	ZN	5.1	500	55.6	24.0	12.7	0.034
	SS	■	5.1	700	55.6	24.0	12.7	0.034
007-1058	MS	ZN	5.1	450	20.0	50.8	19.0	0.033
	SS	■	5.1	550	20.0	50.8	19.0	0.033
08-1058	MS	ZN	5.1	450	34.1	50.8	13.7	0.033
	SS	■	5.1	620	34.1	50.8	13.7	0.033

Dimension Guide (approx. sizes mm)

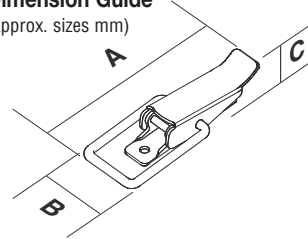

Example of how to order:

LATCH
Part No. + Material + Finish + Qty
33-1260 MS ZN 25
Please remember to order catchplates separately where required:

CATCHPLATE
Part No. + Material + Finish + Qty
05-1058 MS ZN 25



05-1058



06-1058



02-1260



007-1058



08-1058

In addition the Catchplates on page 22 may also be used

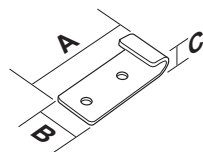

33-1260 & 007-1058



33-1260 & 01-502

33-1260



38-1260 



33-5880



38-5880 



33-2556



38-2556 



33, 37, 38, 39 & 320 - SERIES Rigid & Spring Claw Latches

Part Number	Material	Finish	Diameter of fixing holes (mm)	Max. working load (kg) at max. spring deflection (mm)	Ultimate Tensile Strength (kg)	Safety catch version	Lockable version	Dimensions (mm) (approximate sizes)			Approx. weight Kg	Recommended catchplate, order separately where required	Optional sealing pins
								A	B	C			
39-1260	MS	ZN	5.1	-	450	✓	-	113.3	38.1	20.0	0.114	05-1058, 06-1058, 02-1260, 007-1058, 08-1058	1167/7 SS 1167/9 SS
	SS316	■	5.1	-	550	✓	-	113.3	38.1	20.0	0.114		
320-1260	MS	ZN	5.1	-	450	-	✓	113.3	38.1	20.0	0.119	05-1058, 06-1058, 02-1260, 007-1058, 08-1058	1167/7 SS 1167/9 SS
	SS316	■	5.1	-	550	-	✓	113.3	38.1	20.0	0.119		
37-1260 **	MS	ZN	5.1	-	450	-	✓	113.3	38.1	23.0	0.138	05-1058, 06-1058, 02-1260, 007-1058, 08-1058	-
	SS	■	5.1	-	550	-	✓	113.3	38.1	23.0	0.138		
37-1260 SL**	MS	ZN	5.1	-	450	-	✓	113.3	38.1	23.0	0.138	05-1058, 06-1058, 02-1260, 007-1058, 08-1058	-
	SS	■	5.1	-	550	-	✓	113.3	38.1	23.0	0.138		
37-2099 **	MS	ZN	5.1	64 @ 6	64	-	✓	117.4	52.2	23.0	0.157	05-1058, 06-1058, 02-1260, 007-1058, 08-1058	-
	SS	■	5.1	45 @ 5	45	-	✓	117.4	52.2	23.0	0.157		
37-2099 SL**	MS	ZN	5.1	64 @ 6	64	-	✓	117.4	52.2	23.0	0.157	05-1058, 06-1058, 02-1260, 007-1058, 08-1058	-
	SS	■	5.1	45 @ 5	45	-	✓	117.4	52.2	23.0	0.157		
33-2099	MS	ZN	5.1	64 @ 6	64	-	-	117.4	52.2	17.3	0.133	05-1058, 06-1058, 02-1260, 007-1058, 08-1058	1167/7 SS 1167/9 SS
	SS	■	5.1	45 @ 5	45	-	-	117.4	52.2	17.3	0.133		
38-2099	MS	ZN	5.1	64 @ 6	64	✓	-	117.4	52.2	17.3	0.136	05-1058, 06-1058, 02-1260, 007-1058, 08-1058	1167/7 SS 1167/9 SS
	SS	■	5.1	45 @ 5	45	✓	-	117.4	52.2	17.3	0.136		

** Locks can be purchased separately, locks are not stainless steel in 37-series SL = Identical locks

CATCHPLATES *please order separately where required*

Part Number	Material	Finish	Diameter of fixing holes (mm)	Ultimate Tensile Strength (kg)	Dimensions (mm) (approximate sizes)			Approx. weight Kg
					A	B	C	
05-1058	MS	ZN	5.1	450	34.9	50.8	12.7	0.033
	SS	■	5.1	620	34.9	50.8	12.7	0.033
	SS316	■	5.1	620	34.9	50.8	12.7	0.033
06-1058	MS	ZN	5.1	450	35.4	50.8	15.9	0.033
	SS	■	5.1	620	35.4	50.8	15.9	0.033
	SS316	■	5.1	620	35.4	50.8	15.9	0.033
02-1260	MS	ZN	5.1	500	55.6	24.0	12.7	0.034
	SS	■	5.1	700	55.6	24.0	12.7	0.034
007-1058	MS	ZN	5.1	450	20.0	50.8	19.0	0.033
	SS	■	5.1	550	20.0	50.8	19.0	0.033
08-1058	MS	ZN	5.1	450	34.1	50.8	13.7	0.033
	SS	■	5.1	620	34.1	50.8	13.7	0.033

Dimension Guide (approx. sizes mm)

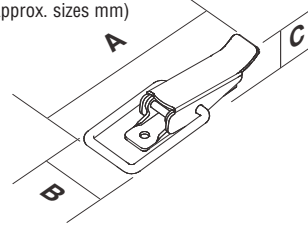

Example of how to order:

LATCH
Part No. + Material + Finish + Qty
39-1260 MS ZN 25
Please remember to order catchplates separately where required:
CATCHPLATE
Part No. + Material + Finish + Qty
05-1058 MS ZN 25



05-1058



06-1058



02-1260



007-1058



08-1058

In addition the Catchplates on page 22 may also be used



39-1260 & 03-1692

39-1260 



320-1260 

Lock automatically engages on closing lever



37-1260 
or
37-1260 SL 



SL = Identical Locks

37-2099 
or
37-2099 SL 



SL = Identical Locks

33-2099



38-2099 



35 & 36 - SERIES Rigid & Spring Latches

Part Number	Material	Finish	Diameter of fixing holes (mm)	Max. working load (kg) at max. spring deflection (mm)	Ultimate Tensile Strength (kg)	Safety catch version	Padlock version	Dimensions (mm) (approximate sizes)			Approx. weight Kg	Recommended catchplate, order separately where required	Optional sealing pins
								A	B	C			
35-1058	MS	ZN	5.1	-	450	-	-	129.8	50.8	17.7	0.127	05-1058, 06-1058, 007-1058, 08-1058	1167/7SS 1167/9SS
	SS	■	5.1	-	550	-	-	129.8	50.8	17.7	0.127		
36-1058	MS	ZN	5.1	-	450	✓	-	129.8	50.8	21.8	0.130	05-1058, 06-1058, 007-1058, 08-1058	1167/7SS
	SS	■	5.1	-	550	✓	-	129.8	50.8	21.8	0.130		
35-1101	MS	ZN	5.1	-	450	-	-	167.2	50.8	17.7	0.138	05-1058, 06-1058, 007-1058, 08-1058	1167/7SS 1167/9SS
	SS	■	5.1	-	550	-	-	167.7	50.8	17.7	0.138		
36-1101	MS	ZN	5.1	-	450	✓	-	167.2	50.8	21.8	0.141	05-1058, 06-1058, 007-1058, 08-1058	1167/7SS
	SS	■	5.1	-	550	✓	-	167.2	50.8	21.8	0.141		
35-1163	MS	ZN	5.1	64 @ 6	64	-	-	130	50.8	17.7	0.147	05-1058, 06-1058, 007-1058, 08-1058	1167/7SS 1167/9SS
	SS	■	5.1	45 @ 5	45	-	-	130	50.8	17.7	0.147		
36-1163	MS	ZN	5.1	64 @ 6	64	✓	-	130	50.8	21.8	0.148	05-1058, 06-1058, 007-1058, 08-1058	1167/7SS
	SS	■	5.1	45 @ 5	45	✓	-	130	50.8	21.8	0.148		

CATCHPLATES *please order separately where required*

Part Number	Material	Finish	Diameter of fixing holes (mm)	Ultimate Tensile Strength (kg)	Dimensions (mm) (approximate sizes)			Approx. weight Kg
					A	B	C	
05-1058	MS	ZN	5.1	450	34.9	50.8	12.7	0.033
	SS	■	5.1	620	34.9	50.8	12.7	0.033
06-1058	MS	ZN	5.1	450	35.4	50.8	15.9	0.033
	SS	■	5.1	620	35.4	50.8	15.9	0.033
007-1058	MS	ZN	5.1	450	20.0	50.8	19.0	0.033
	SS	■	5.1	550	20.0	50.8	19.0	0.033
08-1058	MS	ZN	5.1	450	34.1	50.8	13.7	0.033
	SS	■	5.1	620	34.1	50.8	13.7	0.033

Dimension Guide (approx. sizes mm)

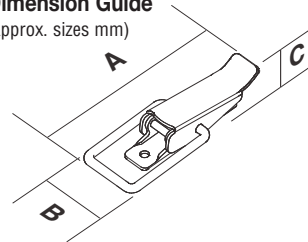

Example of how to order:

LATCH
Part No. + Material + Finish + Qty
35-1058 MS ZN 25
Please remember to order catchplates separately where required:

CATCHPLATE
Part No. + Material + Finish + Qty
05-1058 MS ZN 25

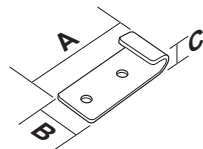

35-1163 & 05-1058



05-1058



06-1058



007-1058



08-1058

35-1058



36-1058 



35-1101



36-1101 



35-1163



36-1163 



70 & 71 - SERIES Adjustable Latches

Part Number	Material	Finish	Diameter of fixing holes (mm)	Maximum adjustment (mm)	Ultimate Tensile Strength (kg)	Safety catch version	Padlock version	Dimensions (mm) (approximate sizes)			Approx. weight Kg	Recommended catchplate, order separately where required	Optional sealing pins
								A	B	C			
70-2573	MS	ZN/YP	5.1	10	650	–	–	142.7	33.0	21.6	0.170	01-1273, 02-1273, 06-625	1167/7 SS 1167/9 SS
	SS	■	5.1	10	750	–	–	142.7	33.0	21.6	0.170		
71-2573	MS	ZN/YP	5.1	10	650	✓	–	142.7	33.0	22.8	0.174	01-1273, 02-1273, 06-625	1167/7 SS
	SS	■	5.1	10	750	✓	–	142.7	33.0	22.8	0.174		
70-2550	MS	ZN/YP	5.1	10	650	–	✓	142.7	33.0	31.6	0.160	01-1273, 02-1273, 06-625	1167/7 SS 1167/9 SS
	SS	■	5.1	10	750	–	✓	142.7	33.0	31.6	0.160		
70-2553	MS	ZN/YP	5.1	10	450	–	–	158.8	30.5	21.6	0.166	–	1167/7 SS 1167/9 SS
	SS	■	5.1	10	350	–	–	158.8	30.5	21.6	0.166		
71-2553	MS	ZN/YP	5.1	10	450	✓	–	158.8	30.5	22.8	0.170	–	1167/7 SS
	SS	■	5.1	10	350	✓	–	158.8	30.5	22.8	0.170		

CATCHPLATES *please order separately where required*

Part Number	Material	Finish	Diameter of fixing holes (mm)	Ultimate Tensile Strength (kg)	Dimensions (mm) (approximate sizes)			Approx. weight Kg
					A	B	C	
01-1273	CS	ZN/YP	5.1	800	34.9	50.8	16.5	0.035
	SS	■	5.1	600	34.9	50.8	16.5	0.035
02-1273	CS	ZN/YP	5.1	800	55.6	23.8	12.7	0.030
	SS	■	5.1	700	55.6	23.8	12.7	0.030
06-625	CS	ZN/YP	5.1	700	43.7	50.8	13.5	0.033
	SS	■	5.1	400	43.7	50.8	13.5	0.033

Dimension Guide (approx. sizes mm)

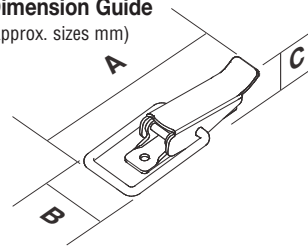

Example of how to order:

LATCH
Part No. + Material + Finish + Qty
70-2573 MS ZN/YP 25
Please remember to order catchplates separately where required:

CATCHPLATE
Part No. + Material + Finish + Qty
01-1273 CS ZN/YP 25

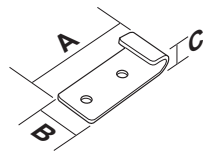

01-1273



02-1273



06-625



70-2573



70-2573 - open



01-1273

70-2550 



71-2573 
Shown in
ZN/YP
version



70-2553



71-2553 



70 & 71 - SERIES Adjustable & Spring Loaded Latches

Part Number	Material	Finish	Diameter of fixing holes (mm)	Maximum adjustment (mm)	Ultimate Tensile Strength (kg)	Safety catch version	Padlock version	Dimensions (mm) (approximate sizes)			Approx. weight Kg	Recommended catchplate, order separately where required	Optional sealing pins
								A	B	C			
70-2575	MS	ZN/YP	5.1	10	600	–	–	144.5	31.5	21.6	0.170	01-575, 06-575	1167/7 SS 1167/9 SS
71-2575	MS	ZN/YP	5.1	10	600	✓	–	144.5	31.5	22.8	0.175	01-575, 06-575	1167/7 SS

Part Number	Material	Finish	Diameter of fixing holes (mm)	Max. working load (kg) at max. spring deflection (mm)	Ultimate Tensile Strength (kg)	Safety catch version	Padlock version	Dimensions (mm) (approximate sizes)			Approx. weight Kg	Recommended catchplate, order separately where required	Optional sealing pins
								A	B	C			
70-2600	MS	ZN/YP	5.1	85 @ 7	85	–	–	128.6	33.0	21.6	0.170	01-1273, 02-1273, 06-625	1167/7 SS 1167/9 SS
	SS	■	5.1	85 @ 7	85	–	–	128.6	33.0	21.6	0.170		
71-2600	MS	ZN/YP	5.1	85 @ 7	85	✓	–	128.6	33.0	22.8	0.175	01-1273, 02-1273, 06-625	1167/7 SS
	SS	■	5.1	85 @ 7	85	✓	–	128.6	33.0	22.8	0.175		

CATCHPLATES *please order separately where required*

Part Number	Material	Finish	Diameter of fixing holes (mm)	Ultimate Tensile Strength (kg)	Dimensions (mm) (approximate sizes)			Approx. weight Kg
					A	B	C	
01-1273	CS	ZN/YP	5.1	800	34.9	50.8	16.5	0.035
	SS	■	5.1	600	34.9	50.8	16.5	0.035
02-1273	CS	ZN/YP	5.1	800	55.6	23.8	12.7	0.030
	SS	■	5.1	700	55.6	23.8	12.7	0.030
06-625	CS	ZN/YP	5.1	700	43.7	50.8	13.5	0.033
	SS	■	5.1	400	43.7	50.8	13.5	0.033
01-575	MS	ZN/YP	5.1	450	47.6	50.8	8.3	0.032
06-575	MS	ZN/YP	5.1	450	42.8	50.8	14.3	0.032

Dimension Guide (approx. sizes mm)

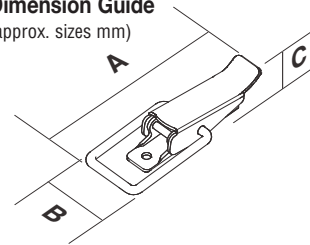

Example of how to order:

LATCH
Part No. + Material + Finish + Qty

70-2575 MS ZN/YP 25

Please remember to order catchplates separately where required:

CATCHPLATE
Part No. + Material + Finish + Qty

01-575 MS ZN/YP 25



01-1273



02-1273



06-625

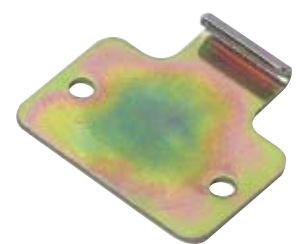

01-575 MSZN/YP

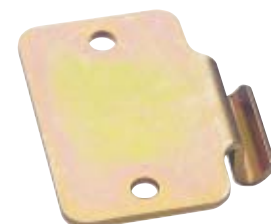

06-575 MSZN/YP



70-2600 & 02-1273

70-2575 MSZN/YP



SCREW ADJUSTMENT

71-2575 MSZN/YP 



SCREW ADJUSTMENT

70-2600

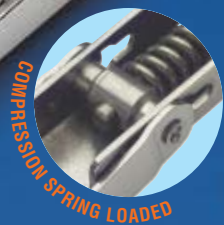

COMPRESSION SPRING LOADED

70-2600 - open



COMPRESSION SPRING LOADED

01-1273

71-2600 



COMPRESSION SPRING LOADED

70 & 71 - SERIES Adjustable Latches

Part Number	Material	Finish	Diameter of fixing holes (mm)	Maximum adjustment (mm)	Ultimate Tensile Strength (kg)	Safety catch version	Padlock version	Dimensions (mm) (approximate sizes)			Approx. weight Kg	Recommended catchplate, order separately where required	Optional sealing pins
								A	B	C			
70-1273	MS	ZN/YP	5.1	10	650	–	–	142.7	50.8	21.6	0.162	01-1273, 06-625	1167/7 SS 1167/9 SS
	SS	■	5.1	10	750	–	–	142.7	50.8	21.6	0.162		
71-1273	MS	ZN/YP	5.1	10	650	✓	–	142.7	50.8	22.8	0.165	01-1273, 06-625	1167/7 SS
	SS	■	5.1	10	750	✓	–	142.7	50.8	22.8	0.165		
70-653M1	MS	ZN/YP	5.1	10	450	–	–	158.8	50.8	21.6	0.170	–	1167/7 SS 1167/9 SS
	SS	■	5.1	10	350	–	–	158.8	50.8	21.6	0.170		
71-653M1	MS	ZN/YP	5.1	10	450	✓	–	158.8	50.8	22.8	0.174	–	1167/7 SS
	SS	■	5.1	10	350	✓	–	158.8	50.8	22.8	0.174		
70-575M1	MS	ZN/YP	5.1	10	600	–	–	144.5	50.8	21.6	0.170	01-575, 06-575	1167/7 SS 1167/9 SS
71-575M1	MS	ZN/YP	5.1	10	600	✓	–	144.5	50.8	22.8	0.174	01-575, 06-575	1167/7 SS

CATCHPLATES *please order separately where required*

Part Number	Material	Finish	Diameter of fixing holes (mm)	Ultimate Tensile Strength (kg)	Dimensions (mm) (approximate sizes)			Approx. weight Kg
					A	B	C	
01-1273	CS	ZN/YP	5.1	800	34.9	50.8	16.5	0.035
	SS	■	5.1	600	34.9	50.8	16.5	0.035
06-625	CS	ZN/YP	5.1	700	43.7	50.8	13.5	0.033
	SS	■	5.1	400	43.7	50.8	13.5	0.033
01-575	MS	ZN/YP	5.1	450	47.6	50.8	8.3	0.032
06-575	MS	ZN/YP	5.1	450	42.8	50.8	14.3	0.032

Dimension Guide (approx. sizes mm)

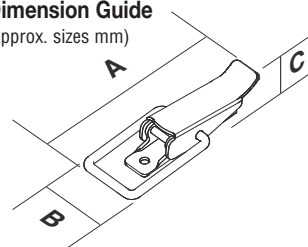

Example of how to order:

LATCH
Part No. + Material + Finish + Qty
70-1273 MS ZN/YP 25

Please remember to order catchplates separately where required:

CATCHPLATE
Part No. + Material + Finish + Qty
01-1273 CS ZN/YP 25

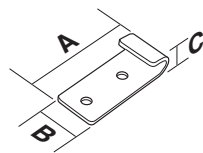

01-1273



06-625

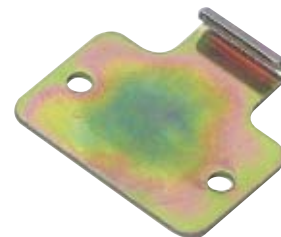

01-575 MSZN/YP

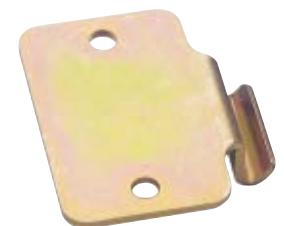

06-575 MSZN/YP

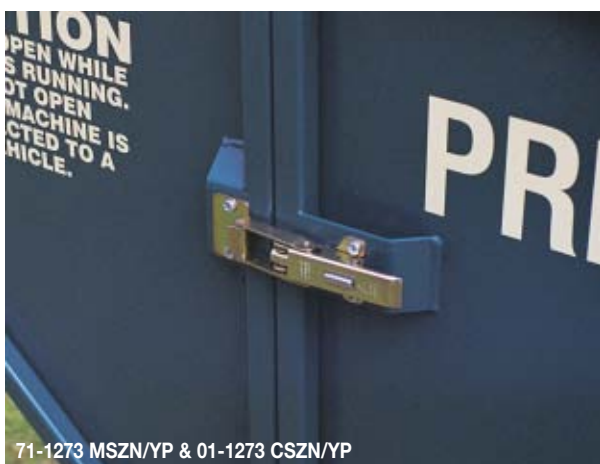

71-1273 MSZN/YP & 01-1273 CSZN/YP



70-653 M1 MSZN/YP

70-1273



71-1273 



70-653 M1



71-653 M1 



70-575 M1MS ZN/YP



71-575 M1MS ZN/YP 



40, 43 & 47 - SERIES Adjustable Latches

Part Number	Material	Finish	Diameter of fixing holes (mm)	Maximum adjustment (mm)	Ultimate Tensile Strength (kg)	Safety catch version	Padlock version	Dimensions (mm) (approximate sizes)			Approx. weight Kg	Recommended catchplate, order separately where required	Optional sealing pins
								A	B	C			
47-2650	MS	ZN	5.1	20	1000	-	✓	186.0	40.0	22.0	0.209	04-2560	1167/7 SS 1167/9 SS
43-3000*	MS	ZN	8.1	20	2000	-	✓	183.0	34.8	36.3	0.417	04-4000	1167/7 SS 1167/9 SS
	SS316	■	8.1	20	2500	-	✓	183.0	34.8	36.3	0.417		
43-3000SFB	MS	ZN	-	20	2000	-	✓	183.0	34.8	36.3	0.417	04-4000, 04-663LB	1167/7 SS 1167/9 SS
40-663LB	MS	ZN	-	20	2000	-	-	183.0	31.0	31.0	0.321	04-663LB	-
	SS	■	-	20	2500	-	-	183.0	31.0	31.0	0.321		
40-1292LB	MS	ZN	-	20	2000	-	-	233.0	31.0	32.3	0.355	04-663LB	-
	SS	■	-	20	2500	-	-	233.0	31.0	32.3	0.355		
40-1292LB/152	MS	ZN	-	50	2000	-	-	283.0	31.0	32.3	0.375	04-663LB	-
	SS	■	-	50	2500	-	-	283.0	31.0	32.3	0.375		

SFB & LB versions in MSZN have self finish bases for welding

CATCHPLATES *please order separately where required*

Part Number	Material	Finish	Diameter of fixing holes (mm)	Ultimate Tensile Strength (kg)	Dimensions (mm) (approximate sizes)			Approx. weight Kg
					A	B	C	
04-2650	MS	ZN	5.1	1000	46.4	19.5	22.7	0.035
04-4000*	MS	ZN	8.1	2000	56.3	24.4	34.8	0.088
	SS316	■	8.1	2500	56.3	24.4	34.8	0.088
04-663LB	MS	SF	-	2000	56.3	25.0	34.8	0.088
	SS	■	-	2500	28.6	22.2	28.6	0.048

Dimension Guide (approx. sizes mm)

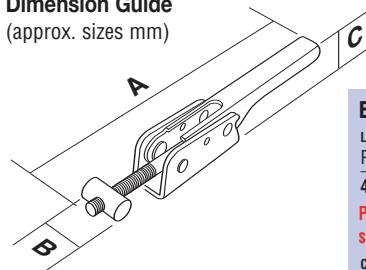

Example of how to order:

LATCH
Part No. + Material + Finish + Qty

47-2650 MS ZN 25

Please remember to order catchplates separately where required:

CATCHPLATE
Part No. + Material + Finish + Qty

04-2650 MS ZN 25

* Fix with 8mm low head socket cap screws

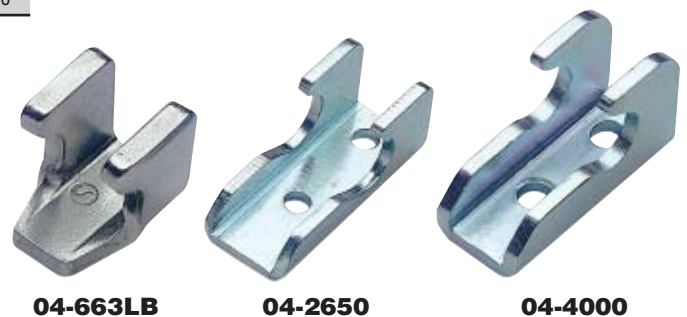
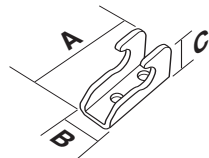

47-2650 



04-2650

43-3000 



04-4000

40-663LB

40-1292LB

40-1292LB/152



04-663LB



04-663LB



04-663LB

40, 43 & 47 - SERIES Adjustable Latches

40 & 41 - SERIES Adjustable Latches

Part Number	Material	Finish	Diameter of fixing holes (mm)	Maximum adjustment (mm)	Ultimate Tensile Strength (kg)	Safety catch version	Padlock version	Dimensions (mm) (approximate sizes)			Approx. weight (Kg)	Recommended catchplate, order separately where required	Optional sealing pins
								A	B	C			
40-1292	MS	ZN	8.1	20	2000	–	–	233.0	76.2	40.0	0.656	04-663WB	1167/7
	SS	■	8.1	20	2500	–	–	233.0	76.2	40.0	0.656		1167/9
40-1292/152	MS	ZN	8.1	50	2000	–	–	283.0	76.2	40.0	0.700	04-663WB	1167/7
	SS	■	8.1	50	2500	–	–	283.0	76.2	40.0	0.700		1167/9
41-1292	MS	ZN	8.1	20	2000	✓	–	233.0	76.2	48.0	0.674	04-663WB	1167/7
	SS	■	8.1	20	2500	✓	–	233.0	76.2	48.0	0.674		1167/9
41-1292/152	MS	ZN	8.1	50	2000	✓	–	283.0	76.2	48.0	0.720	04-663WB	1167/7
	SS	■	8.1	50	2500	✓	–	283.0	76.2	48.0	0.720		1167/9

CATCHPLATES *please order separately where required*

Part Number	Material	Finish	Diameter of fixing holes (mm)	Ultimate Tensile Strength (kg)	Dimensions (mm) (approximate sizes)			Approx. weight (Kg)
					A	B	C	
04-663WB	MS	ZN	8.1	2000	63.5	76.2	33.3	0.232
	SS	■	8.1	2500	63.5	76.2	33.3	0.232

Dimension Guide (approx. sizes mm)

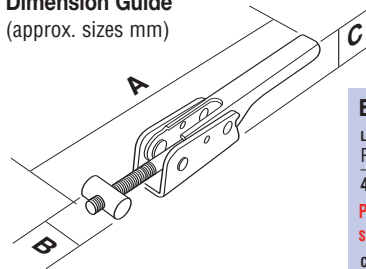

Example of how to order:

LATCH
Part No. + Material + Finish + Qty

40-1292 MS ZN 25
Please remember to order catchplates separately where required:

CATCHPLATE
Part No. + Material + Finish + Qty
04-663WB MS ZN 25

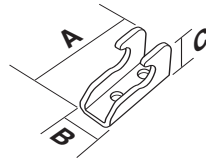

04-663WB



These items now obsolete
click on product to view
replacement part on protex.com

Now obsolete
use 43-4292

40-1292

40-1292/152

Now obsolete
use 43-4292/150

04-663WB
Now obsolete
use 04-4292

04-663WB

41-1292 
Now obsolete
use 44-4292

04-663WB

Now obsolete
use 04-4292

04-663WB

41-1292/152 
Now obsolete
use 44-4292/150

40 & 41 - SERIES Adjustable Latches

43 & 44 - SERIES Adjustable Latches

Part Number	Material	Finish	Diameter of fixing holes (mm)	Maximum adjustment (mm)	Ultimate Tensile Strength (kg)	Safety catch version	Padlock version	Dimensions (mm) (approximate sizes)			Approx. weight	Recommended catchplate, order separately where required	Optional sealing pins
								A	B	C			
43-4000*	MS	ZN	8.1	20	2000	–	✓	232.0	34.6	36.3	0.402	04-4000	1167/7 SS
	SS316	■	8.1	20	2500	–	✓	232.0	34.6	36.3	0.402		1167/9 SS
44-4000*	MS	ZN	8.1	20	2000	✓	–	232.0	37.1	36.3	0.495	04-4000	1167/7 SS
	SS316	■	8.1	20	2500	✓	–	232.0	37.1	36.3	0.495		1167/9 SS
43-4000/150*	MS	ZN	8.1	50	2000	–	✓	278.0	34.6	36.3	0.492	04-4000	1167/7 SS
	SS316	■	8.1	50	2500	–	✓	278.0	34.6	36.3	0.492		1167/9 SS
44-4000/150*	MS	ZN	8.1	50	2000	✓	–	278.0	37.1	36.3	0.525	04-4000	1167/7 SS
	SS316	■	8.1	50	2500	✓	–	278.0	37.1	36.3	0.525		1167/9 SS
43-4000SFB	MS	ZN	–	20	2000	–	✓	232.0	34.6	36.3	0.402	04-4000,04-663LB	1167/7 SS 1167/9 SS
44-4000SFB	MS	ZN	–	20	2000	✓	–	232.0	37.1	36.3	0.495	04-4000,04-663LB	1167/7 SS 1167/9 SS
43-4000/150SFB	MS	ZN	–	50	2000	–	✓	278.0	34.6	36.3	0.492	04-4000,04-663LB	1167/7 SS 1167/9 SS
44-4000/150SFB	MS	ZN	–	50	2000	✓	–	278.0	37.1	36.3	0.525	04-4000,04-663LB	1167/7 SS 1167/9 SS

SFB versions in MSZN have self finish bases for welding

CATCHPLATES *please order separately where required*

Part Number	Material	Finish	Diameter of fixing holes (mm)	Ultimate Tensile Strength (kg)	Dimensions (mm) (approximate sizes)			Approx. weight
					A	B	C	
04-4000*	MS	ZN	8.1	2000	56.3	25.0	34.8	0.088
	SS316	■	8.1	2500	56.3	25.0	34.8	0.088
	MS	SF	–	2000	56.3	25.0	34.8	0.088
04-663LB	MS	SF	–	2000	28.6	22.2	28.6	0.048
	SS	■	–	2500	28.6	22.2	28.6	0.048

Dimension Guide
(approx. sizes mm)

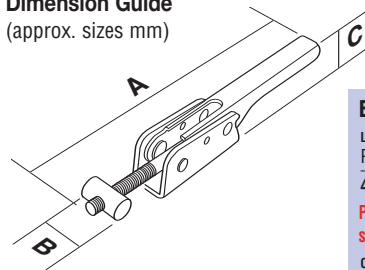

Example of how to order:

LATCH
Part No. + Material + Finish + Qty
43-4000 MS ZN 25
Please remember to order catchplates separately where required:

CATCHPLATE
Part No. + Material + Finish + Qty
04-4000 MS ZN 25

* Fix with 8mm low head socket cap screws

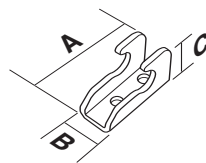

04-4000



04-663LB



43-4000 

43-4000/150 



04-4000



04-4000



44-4000 

44-4000/150 



04-4000



04-4000

43 & 44 - SERIES Adjustable Latches

Protex® PROLATCH

Part Number	Material	Finish	Diameter of fixing holes (mm)	Max. working load (kg) at max. spring deflection (mm)	Ultimate Tensile Strength (kg)	Safety catch version	Padlock version	Dimensions (mm) (approximate sizes)			Approx. weight Kg	Recommended catchplate, order separately where required	Optional sealing pins
								A	B	C			
640-1000	MS	ZN/YP	4.1	–	300	✓	–	99.8	45.2	15.8	0.128	001-1000	613/7 SS
	SS	■	4.1	–	400	✓	–	99.8	45.2	15.8	0.137		
641-1000	MS	ZN/YP	4.1	–	300	✓	✓	100.0	45.2	18.0	0.128	001-1000	–
	SS	■	4.1	–	400	✓	✓	100.0	45.2	18.0	0.137		
645-1010	MS	ZN/YP	4.1	–	250	✓	–	162.8	114.3	18.8	0.330	–	613/7 SS
	SS	■	4.1	–	375	✓	–	162.8	114.3	18.8	0.330		
646-1010	MS	ZN/YP	4.1	–	250	✓	✓	162.8	114.3	18.8	0.330	–	–
	SS	■	4.1	–	375	✓	✓	162.8	114.3	18.8	0.330		
270-600	MS	ZN/YP	4.1	–	200	✓	–	66.9	22.0	18.3	0.044	001-600	613/7 SS 613/9 SS
	SS	■	4.1	–	300	✓	–	66.9	22.0	18.3	0.044		

CATCHPLATES *please order separately where required*

Part Number	Material	Finish	Diameter of fixing holes (mm)	Ultimate Tensile Strength (kg)	Dimensions (mm) (approximate sizes)			Approx. weight Kg
					A	B	C	
001-1000	MS	ZN/YP	5.1	250	20.0	45.0	15.2	0.007
	SS	■	5.1	375	20.0	45.0	15.2	0.007
001-600	MS	ZN/YP	4.1	300	16.5	40.0	11.0	0.007
	SS	■	4.1	400	16.5	40.0	11.0	0.007

Dimension Guide (approx. sizes mm)

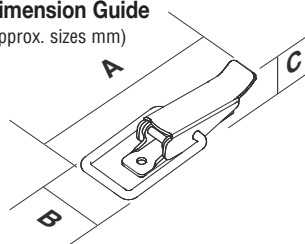

Example of how to order:

LATCH
Part No. + Material + Finish + Qty

640-1000 MS ZN/YP 25

Please remember to order catchplates separately where required:

CATCHPLATE
Part No. + Material + Finish + Qty

001-1000 MS ZN/YP 25

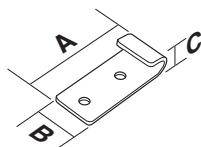

The unique PROLATCH™ forces a panel or door against a seal, and holds firmly in two planes. A safety catch is incorporated, and provision for a padlock is offered.

The Junior PROLATCH™ is smaller and lighter but uses the same unique principle to close a door or panel and incorporates a simple safety-catch.

001-600 MSZN/YP

001-600 SS

001-1000 MSZN/YP

001-1000 SS

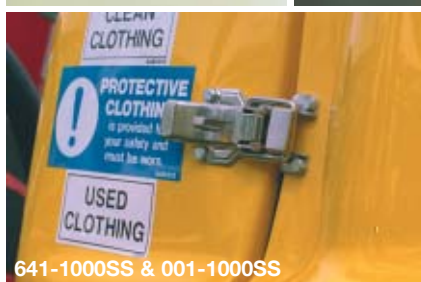
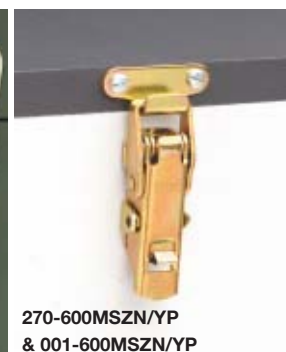
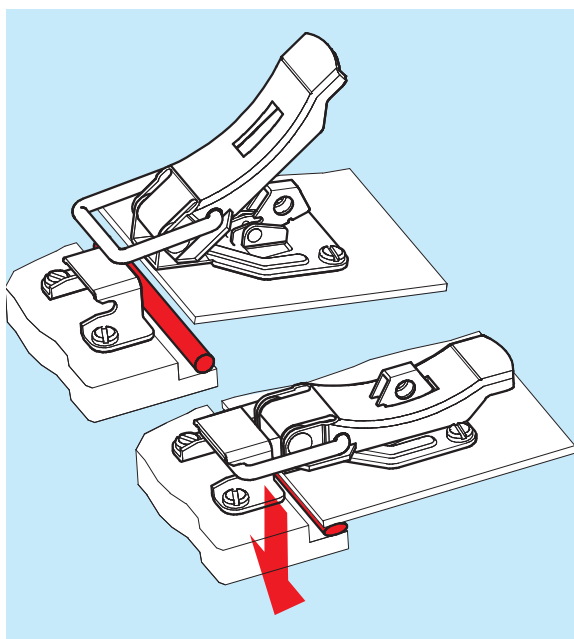

640-1000 MS ZN/YP 

641-1000 MS ZN/YP  

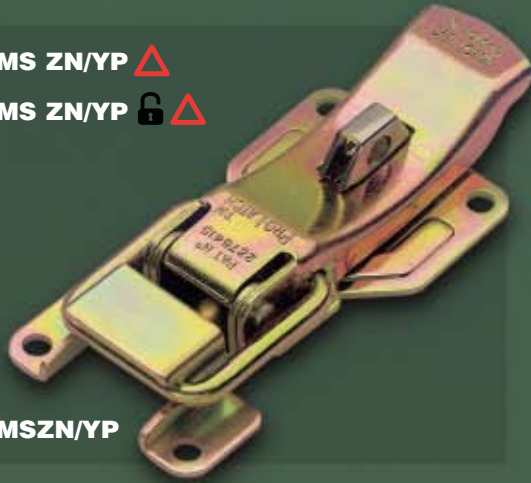

001-1000 MSZN/YP

640-1000 SS 

641-1000 SS  

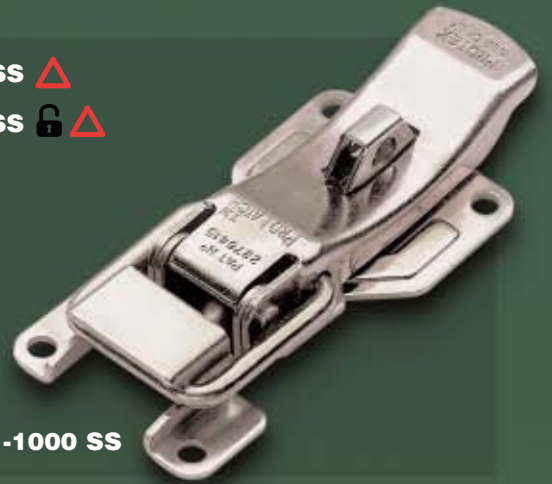

001-1000 SS



640-1000 Safety catch version 



641-1000 Padlock version  

645-1010 MS ZN/YP 

646-1010 MS ZN/YP  

Also available in stainless steel

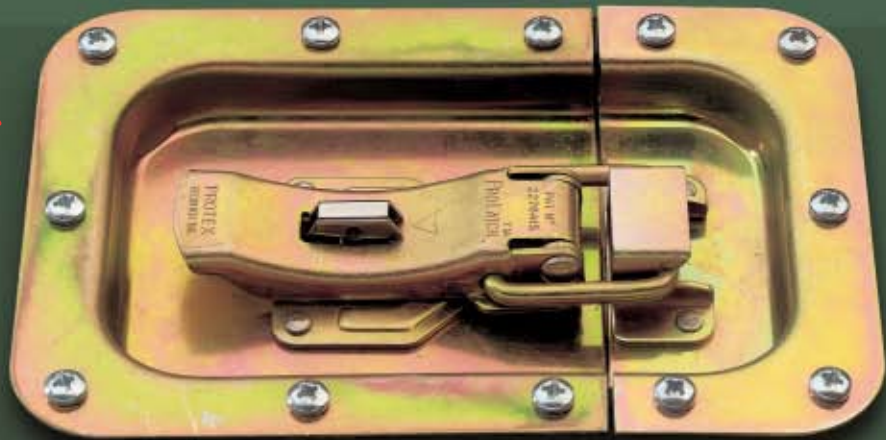

Junior **PROLATCH**[™]

270-600 MS ZN/YP 

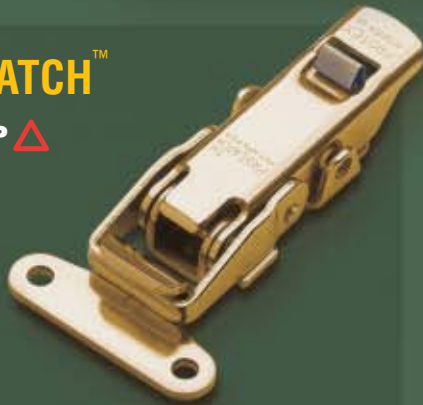

001-600 MSZN/YP

270-600 SS 



001-1000 SS

Protex® CATCHBOLT

Part Number	Material	Finish	Diameter of fixing holes (mm)	Ultimate Tensile Strength (kg)			Safety catch version	Padlock version	Dimensions (mm) (approximate sizes)			Approx. weight (Kg)	Recommended catchplate, order separately where required	Optional sealing pins
				1	2	3			A	B	C			
88-1068	MS	ZN/YP	4.1	400	900	400	-	✓	100.0	45.2	18.0	0.128	-	502/7 SS
	SS	■	4.1	600	900	600	-	✓	100.0	45.2	18.0	0.137		502/9 SS
89-1069	MS	ZN/YP	4.1	400	900	400	✓	-	100.0	45.2	18.0	0.128	-	502/7 SS
	SS	■	4.1	600	900	600	✓	-	100.0	45.2	18.0	0.137		502/9 SS
90-1090	MS	ZN/YP	4.1	400	900	400	-	✓	162.8	114.3	18.8	0.330	-	502/7 SS
	SS	■	4.1	600	900	600	-	✓	162.8	114.3	18.8	0.330		502/9 SS
91-1090	MS	ZN/YP	4.1	400	900	400	✓	-	162.8	114.3	18.8	0.330	-	502/7 SS
	SS	■	4.1	600	900	600	✓	-	162.8	114.3	18.8	0.330		502/9 SS
8803-1068	MS	ZN/YP	4.1	400	100	150	-	✓	106.1	45.2	45.6	0.180	-	502/7 SS
	SS	■	4.1	600	100	150	-	✓	106.1	45.2	45.6	0.180		502/9 SS
8903-1069	MS	ZN/YP	4.1	400	100	150	✓	-	106.1	45.2	45.6	0.175	-	502/7 SS
	SS	■	4.1	600	100	150	✓	-	106.1	45.2	45.6	0.175		502/9 SS
8807-1068	MS	ZN/YP	4.1	400	100	100	-	✓	105.1	45.2	28.0	0.180	-	502/7 SS
	SS	■	4.1	600	100	100	-	✓	105.1	45.2	28.0	0.180		502/9 SS
8907-1069	MS	ZN/YP	4.1	400	100	100	✓	-	105.1	45.2	28.0	0.175	-	502/7 SS
	SS	■	4.1	600	100	100	✓	-	105.1	45.2	28.0	0.175		502/9 SS



8907-1069SS



8803-1068SS

Dimension Guide (approx. sizes mm)

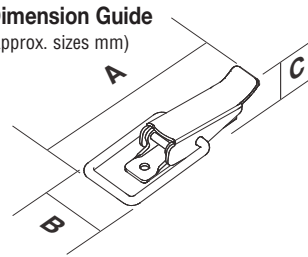

Example of how to order:

CATCHBOLT
Part No. + Material + Finish + Qty
88-1068 MS ZN/YP 25

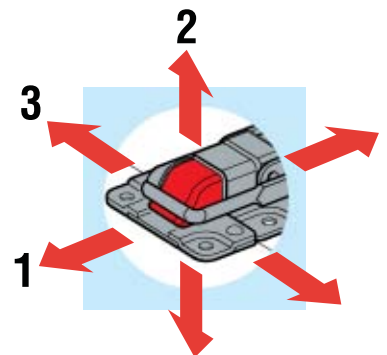
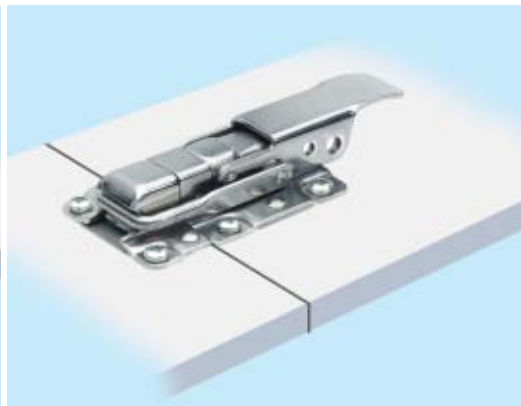
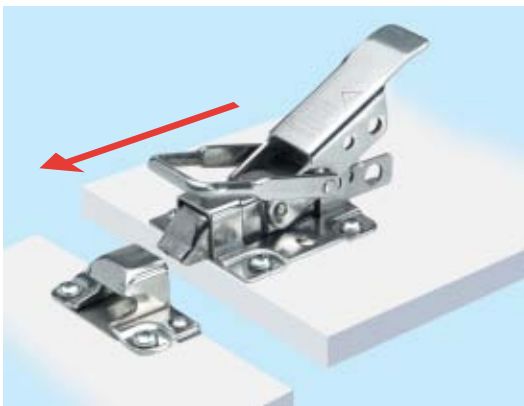

89-1069SS



88-1068SS



88-1068SS

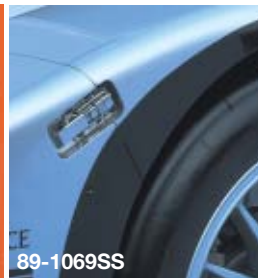

89-1069SS

The unique Protex® CATCHBOLT holds firmly in three directions.
The integral bolt forces a panel or door to close in.

88-1068 

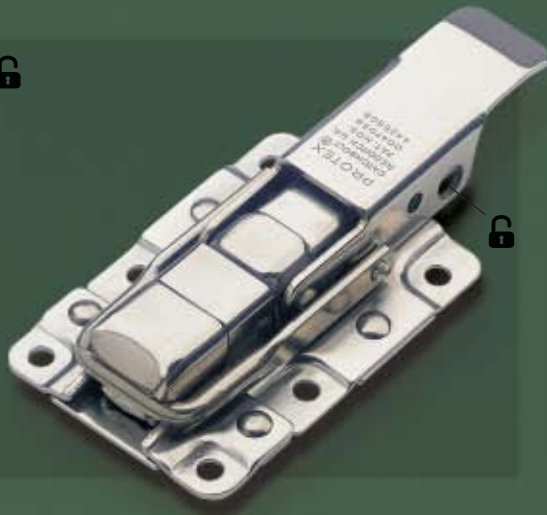

89-1069 

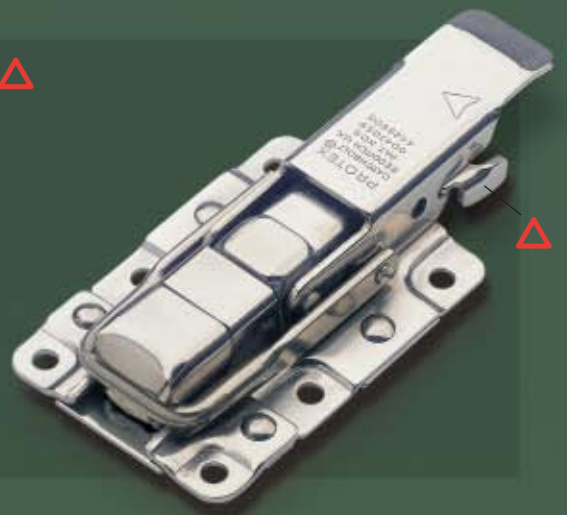

90-1090 

91-1090 

Shown in
ZN/YP version



8803-1068 



8903-1069 



8807-1068 



8907-1069 

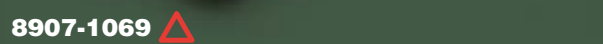

NON-STOCK ITEMS

22-1895



QT-8500



201-5000 MSBL



30-1609



30-588CWLP



30-503



30-1233



30-654



Subject to minimum order quantity's please contact Protex to discuss your requirements

38-1260 MSBL



35-1058 MSBL



71-2414



70-575 M1 MSBL



71-2700



65-614



NON-STOCK ITEMS

PROTEX®



ROREP

Your dealer for the BENELUX

Tel: +32.(0)495.89.81.95

Fax: +32.(0)54.58.87.49

info@rorep.be

www.rorep.be

